

ALBERT JOHNSON

OPERATOR'S MANUAL

SUPER 66

TWINE TIE BALER

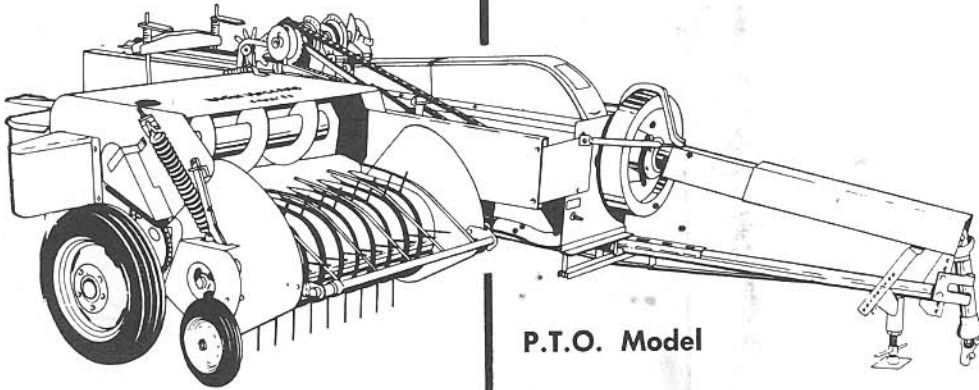

P.T.O. Model

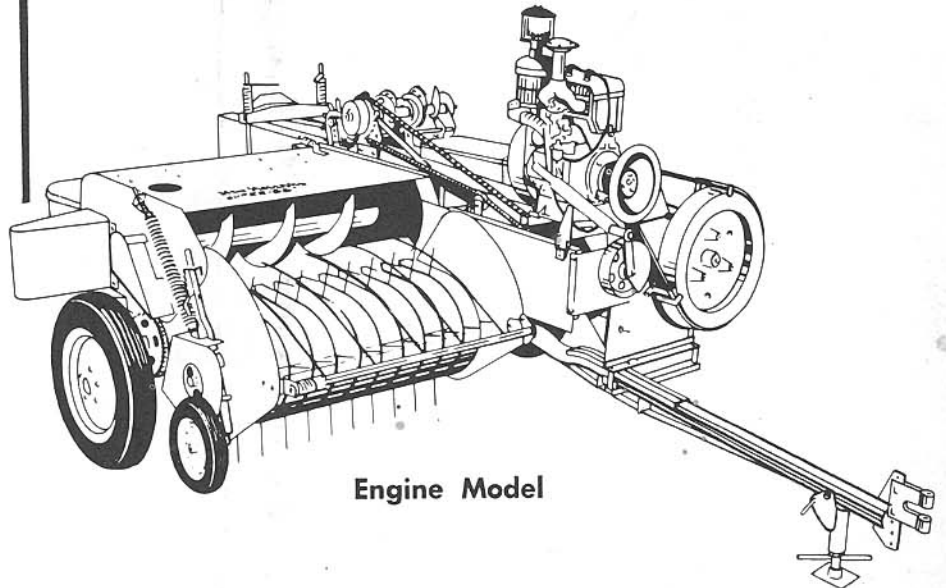

Engine Model



NEW HOLLAND

CONTENTS

Specifications	4	Plunger Slides	16
Introduction	5	Feeder Plunger	16
Before Using Your New Baler	6	Metering Wheel	17
Hay Making Hints	7	Knotter Adjustment	17-20
Super 66 P.T.O. Baler	7	Twine Fingers	17
Lubrication	8	Twine Disc	18
Baler Break-In	10	Twine Holder	18
Attaching Baler to Tractor	10	Bill Hook	19
Preparing to Bale	10	Knife Arm	20
Threading the Needles	10	Knotter Shaft Assembly	21
Regulating Bale Weight	11	Trouble Shooting Chart	22, 24
Safety Features	12, 13	Special Equipment	25-27
Needle Safety Latch	12	Baler Maintenance	28
Shear Bolts	12	Engine Care	28
Pick-up Slip Clutch	13	Gearbox	28
Adjustment	13-20	Tires	28
Pick-up Assembly	13	Drive Belts	28
Wind Guard	13	P.T.O. Drive	28
Needles	14	Roller Chains	28
Needle Yoke	14	Replacing Pick-up Fingers	28
Needle Timing	14	Daily Care of the Baler	28
Knotter Brakes	15	Storing the Baler	29
Wadboard	15	Ordering Parts	29
Plunger and Knife Adjustment	16	Warranty	31



Good Baling Requires Good Twine

When you bale with your New Holland Super 66 you'll appreciate the advantages of New Holland Certified baler twine. It is the only baler twine on the market to carry the U.S. Testing Laboratories Seal of Approval for uniformity, length and strength. Look for the U. S. Testing Seal on every ball — it's your assurance of full length, full strength, full quality.

SPECIFICATIONS

SUPER 66 ENGINE DRIVEN BALER

Length over-all	bale chute up	15' 9"
Length over-all	bale chute down	18' 5"
Wheel tread width		7' 4"
Width over-all		8' 9"
Pick-up width		49½"
Height		6'
Weight complete		approx. 2500 lbs.
Size of bale chamber		14" x 18"
Length of bales	adjustable	12" to 52"
Plunger stroke		26"
Plunger speed		70 strokes per minute
Capacity		up to 9 tons per hour.
Tire pressure left wheel (6:00 x 16" tire)		36 lbs.
Tire pressure right wheel (5:00 x 16" tire)		32 lbs.
Wheel Bearings		Tapered Roller
Power required to draw baler		one plow tractor

Engine

Make		Wisconsin
Type		TF-D
Rated horse power		15 H.P. at 2890 R.P.M.
Number of cylinders		2
Crank case capacity		3½ qts.
Fuel tank capacity		6 gal.
Type of gasoline		70 to 75 octane

SUPER 66 P.T.O. BALER

Height Over-all		48"
Weight		approx. 2200 lbs.
P.T.O. Speed		540 R.P.M.
Plunger Speed		70 strokes per minute
Power required		Two-plow tractor with A.S.A.E. hitch

SPECIAL EQUIPMENT

Baler cover	Jack
Wagon hitch and bale loading chute	Hydraulic bale tension
TF-D Engine with electrical starting equipment	

INTRODUCTION

The Super 66 New Holland baler is designed to meet the need of the individual farmer who does not want to be dependent on custom operators. It is built for economy both in initial cost and operation, containing fewer working parts and weighing approximately 2,000 lbs. less than the larger Super 77 New Holland baler.

Like all New Holland balers, the Super 66 baler automatically picks up hay from the windrow and delivers it in sliced uniform bales with only the tractor operator required for the entire process. The machine produces up to 7 bales per minute depending upon the condition and type of material, size of windrow, and other varying factors.

The Super 66 baler is powered by a 15 H.P. two cylinder Wisconsin air cooled engine and is designed to operate at a plunger speed of 70 strokes per minute. The feeder is equipped with a floating bottom and a plunger driven wadboard which make possible high capacity and positive feed with a minimum loss of leaves.

The bale counter, supplied as standard equipment, makes it possible to keep an accurate account of the bales and eliminates guess work. Also supplied with each machine is the adjustable metering wheel which enables the operator to select the length of bale that best suits his need.

The Super 66 P.T.O. baler is similar to the Super 66 engine driven baler in most respects but requires no engine, drive belts, etc., since it is powered by the tractor. The slip clutch and the over-running clutch incorporated in the P.T.O. drive protect both the tractor and the baler, and to make it possible to use the machine successfully with a tractor not equipped with a "live" power-take off.

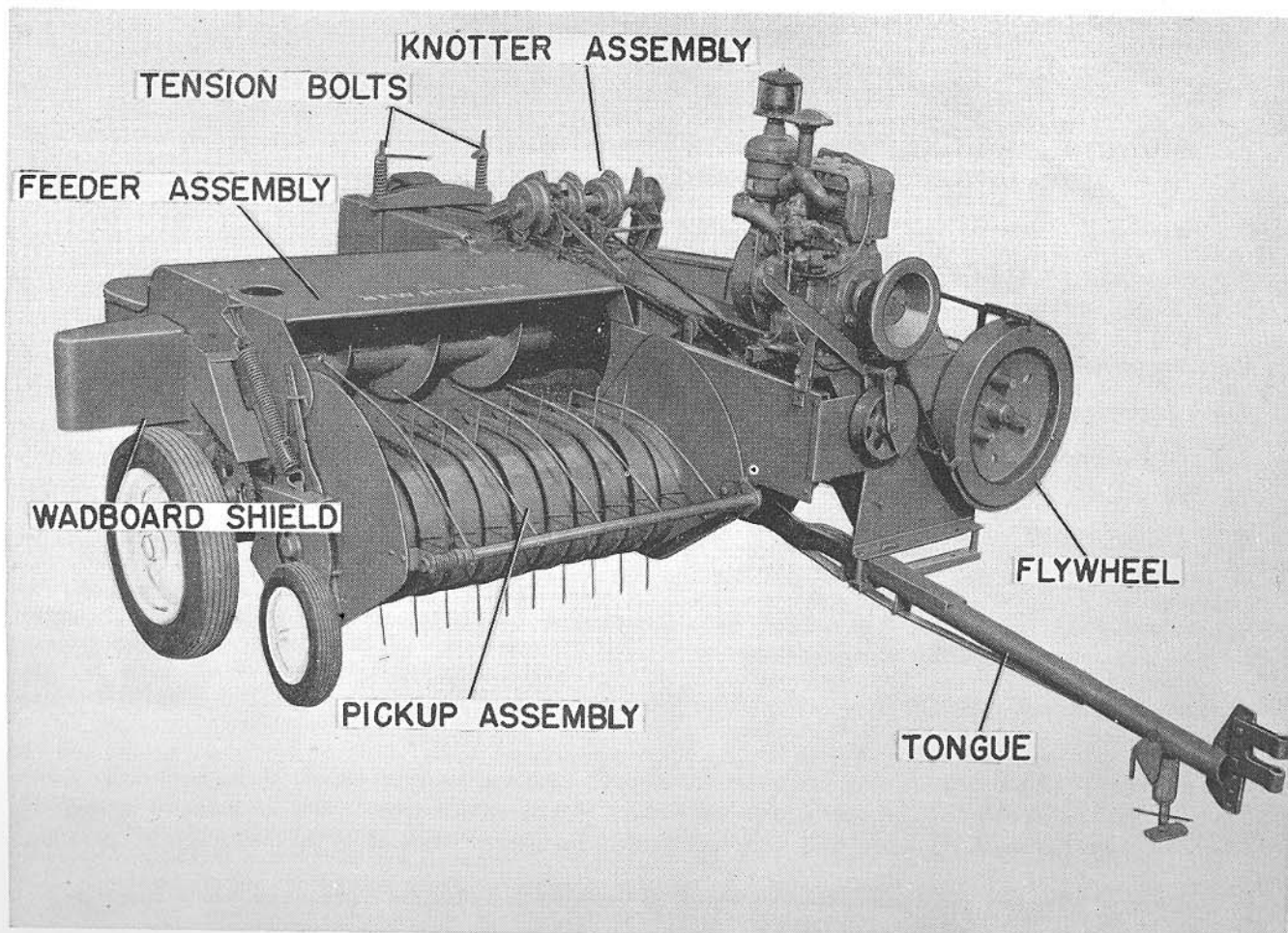

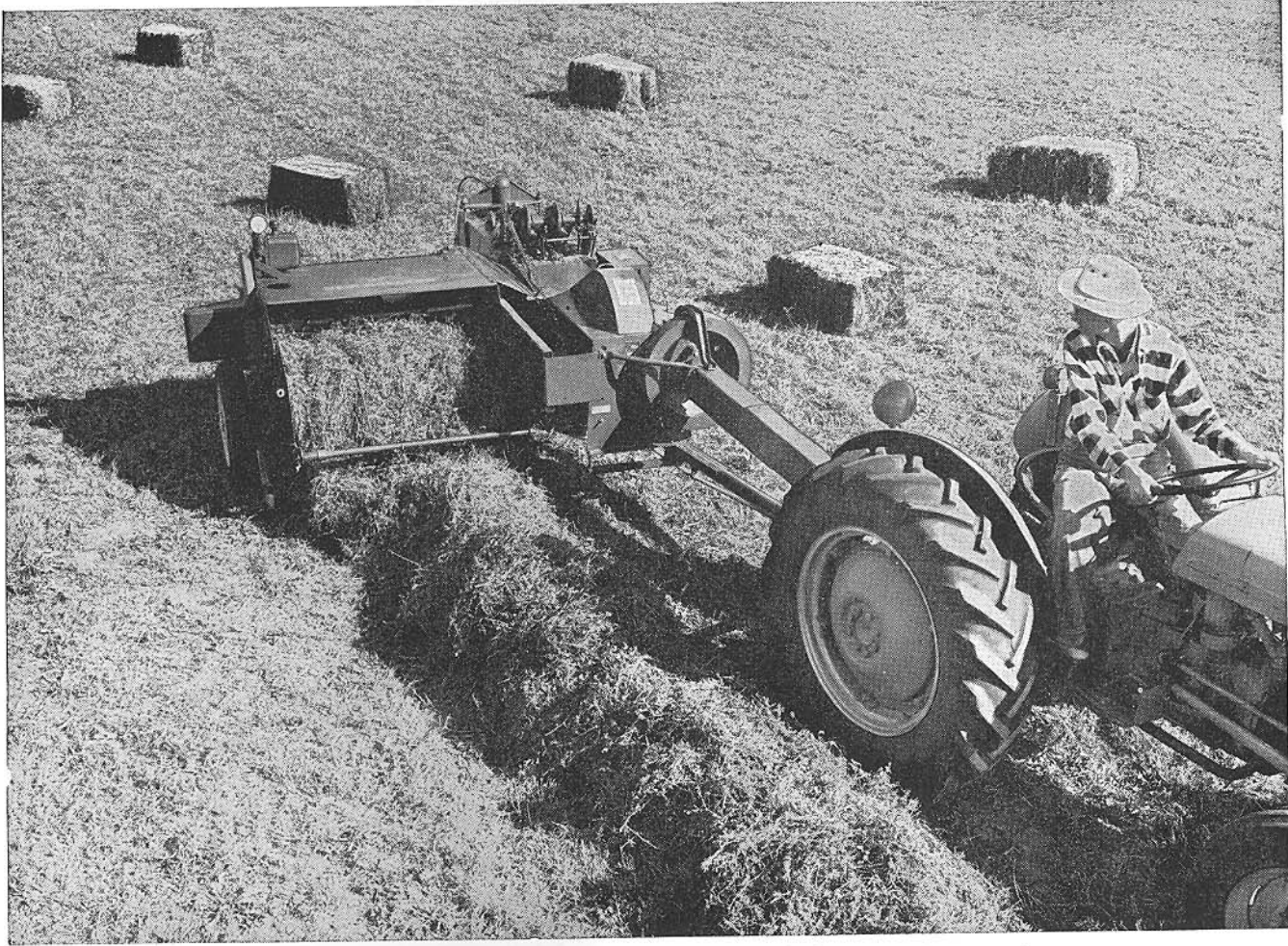

Super 66 P.T.O. baler equipped with hydraformatic bale tension in operation.

BEFORE USING YOUR NEW BALER

1. Read the operating instructions and the engine manual supplied with the baler before starting the engine.
2. Check for proper assembly and adjustment and make sure that all bolts are tight.
3. See that all belts and chains are properly aligned and moderately tight.
4. Check the tires and inflate to the proper pressure (left ground wheel, 36 pounds; right ground wheel, 32 lbs).
5. Service the engine as instructed in the engine manual. Check the oil level in the crank case and the air cleaner reservoir. Fill the fuel tank with gasoline of 70 to 75 octane rating.
6. Lubricate the baler carefully and completely as recommended. Check the oil level of the gearbox and fill to the proper level with SAE #90 gear oil.
7. Remove all tools and materials from the machine and turn the flywheel by hand to see that all parts move freely.
8. Make sure that all persons are clear and start the engine. Operate the baler slowly for a short time. Gradually increase the speed to 70 plunger strokes per minute and operate the baler without load for at least 30 minutes. Turn the metering wheel and trip the knotters a number of times while the machine is in operation.

Observe all safety precautions; never attempt to lubricate or adjust the baler when it is in operation.

SUPER 66 P.T.O. BALER

Attaching the Baler to the Tractor

The Super 66 P.T.O. baler is designed for use only with an A.S.A.E. standard tractor hitch. It is very important that the hitch point be located exactly as specified because an improperly located hitch point will subject the universal joints of the P.T.O. drive to undue stresses which may result in inefficient baler operation or damage to these parts.

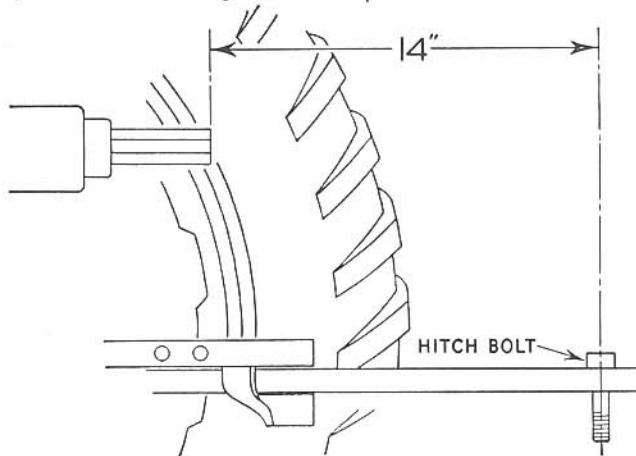

FIGURE 1

Attach the baler to the tractor draw bar directly in line with the tractor power take-off shaft with a distance of 14" between the end of the power take-off shaft and a vertical line from the center of the baler hitch pin as illustrated in Fig. 1. Install a hitch adapter plate, if necessary, to secure the correct distance between these two points. On some tractors (non-A.S.A.E. standard) it may be necessary to install a P.T.O. conversion kit.

Use a hitch bolt of the proper size ($\frac{3}{4}$ ") to eliminate any sloppiness at the hitch point; install a jam nut or a cotter pin to prevent the hitch bolt from being lost out. **Never attach the baler to a draw-bar that moves from side to side. Always bolt a swinging draw-bar in a stationary position before attaching the baler.**

Adjust the hitch clevis of the baler tongue up or down as required so that the baler frame is approximately level.

Attach the front yoke of the baler P.T.O. to the tractor and see that the tractor P.T.O. shield is installed. Note: It is necessary to install a spline adapter on any tractor power take-off shaft having a diameter less than the standard $1\frac{3}{8}$ ".

Remove the mounting bolt from the P.T.O. support yoke which is attached to the front end of the baler tongue and move the support yoke up or down to the point at which the power drive line is as nearly straight as possible.

Before beginning to bale, swing the baler tongue to the left to operating position. **Never operate the baler with the tongue in road travel position.** The hitch point should be directly beneath the power drive line; if the tractor wheel runs on the windrow, move the tractor wheel in or out to secure windrow clearance.

Avoid extremely short turns when the baler is in operation. Decrease the P.T.O. speed, when turning, to reduce wear on the universal joints.

Slip Clutch Adjustment

Make sure that the discs of the slip clutch are frozen by paint or rust before beginning to operate baler.

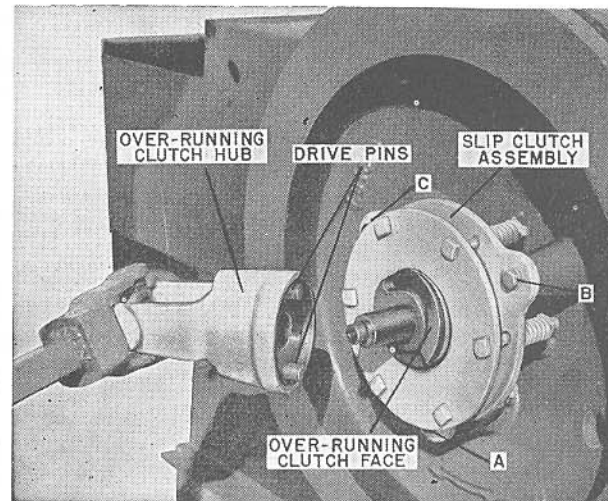

FIGURE 2

To check clutch action, place a wrench on the baler P.T.O. shaft and lock the flywheel or the plunger. If the clutch is operating properly, a force of 100 lbs. applied on the handle of the wrench at a point 2 inches from the center of the P.T.O. shaft should cause the clutch to slip.

When the clutch requires re-adjustment, tighten each tension bolt a fraction of a turn to increase spring pressure on the discs. Caution: **Never adjust tension springs to a compression length less than 1 1/2 inches. Keep the clutch discs free from grease and oil.**

Oil the drive pins of the over-running clutch (Figure 2) with several drops of light machine oil before operating the baler. When the baler is in operation, these pins should be lubricated with two or three drops of oil daily. Refer to page 8 for further lubrication recommendations.

OPERATION

After the baler is serviced and correctly attached to the tractor, make sure that all persons and tools are clear of the machine and cautiously engage the tractor P.T.O. Operate the baler slowly for a time without load and gradually increase the plunger speed to 70 strokes per minute.

Important: The baler is designed to operate at a maximum speed of 70 plunger strokes per minute. The throttle range of tractors having a P.T.O. speed greater than 540 r.p.m. must be limited to prevent possible damage to the machine.

Note: In some conditions the baler can be operated to best advantage at speeds less than 70 plunger strokes per minute.

For best baling results, windrows should be uniform in form and of medium size. The size of the windrow should not exceed that which the baler can pick up and handle efficiently when the tractor is operating in its lowest gear at the proper throttle setting.

Further information in this manual concerning lubrication, adjustment, etc. applies both to the power take-off and the engine driven balers.

LUBRICATION

The Super 66 baler is designed to require a minimum of lubrication, however, sufficient and careful lubrication is the best insurance against delays for repairs in the field and greatly increases the life of the machine.

Under normal conditions the machine should be greased after every 600 bales.

The operator should become familiar with all lubrication points and establish a systematic routine to insure complete and quick lubrication of the baler. He should make certain that all grease fittings are open and free of paint or dirt so that the grease actually gets into the bearings. Refer to the lubrication chart for the location of the grease fittings.

The bearing on the front of the gear box (Point 2 Fig. 3B) is a sealed bearing which will be damaged by excessive lubrication. One or two pumps of a hand gun twice a week is ample. Remove the grease gun as soon as a slight resistance indicates that this bearing is filled. All other lubrication points on the baler should have grease forced into the fittings until the grease comes out around the shaft. Wipe off excess grease to prevent the accumulation of chaff and grit around the bearings.

Oil the clevis pin at the lower end of the needle yoke rod and all other linkage daily.

During the first ten hours of operation, check all lubrication points carefully for signs of over-heating and relubricate as required.

Keep the gear box filled with S.A.E. #90 E. P. oil to the level of the pipe plug on the side of the case.

Roller Chains

Oil the wadboard drive chain, the wadboard driven chain, and the knotter drive chain daily. Particular care should be taken to oil the wadboard chains at the idlers since these chains do not make a complete revolution. All roller chains must be kept moderately tight to insure the satisfactory operation of the baler.

In localities where the soil is sandy or gritty, chains frequently give better service without the continual application of oil. In such localities the new chains should be "run in" by oiling them thoroughly while the machine is being run idle for several hours in a clean place. The excess oil should then be removed from the chains before the machine is put into field operation and they should be run the remainder of the season with little or no further lubrication.

Ground Wheels

The ground wheels of the baler are equipped with tapered roller bearings which are packed with grease upon assembly. These bearings should be checked each season and repacked with wheel bearing grease as needed.

Gear Box

Use S.A.E. #90 E. P. gear oil*. Keep the gear box filled to the oil level plug.

Change the oil of the gear box at the beginning of each baling season.

Under normal use, the gear box should require no servicing or adjustment if kept properly lubricated.

Should a problem arise concerning the gear box, consult an authorized New Holland dealer. **Operators**

are cautioned not to attempt to repair or adjust the gear box.

Engine

Use a good grade motor oil in the engine at all times. Recommended weights are as follows:

Above 40 degrees F. use S.A.E. #30.

5 degrees F. to 40 degrees F. use S.A.E. #20.

Below 5 degrees F. use S.A.E. #10.

Check the crankcase oil level after every eight hours of operation. Change crankcase oil after every fifty hours of operation.

Service the air filter daily. Fill the oil reservoir of the air filter to the level indicated on the side of the cup with the same type oil as used in the crankcase.

P.T.O. Drive

Grease the P.T.O. drive tube (point 39, Fig. 3J) twice daily when the machine is in operation.

Lubricate the universal joints of the P.T.O. drive with one or two pumps of the hand gun twice a week.

Keep the flywheel lubricated.

Oil the drive pins of the over-running clutch (point 37, Fig. 3J) with several drops of light machine oil before operating the baler. When the baler is in operation, these pins should be lubricated with two or three drops of oil daily. **Important: Oil the drive pins sparingly; excessive oiling may cause clutch slippage.**

At the beginning of each baling season, disassemble the disc clutch and the over-running clutch and wipe grease on the bushing of these assemblies. Also remove the P.T.O. drive guards at this time and lubricate the slides so that the guards telescope freely.

LUBRICATION POINTS

The locations of the lubrication points are shown in the illustrations on the opposite page.

The following system of lubrication is suggested:

- 1 flywheel hub
- 1A belt tightener (oil daily)
- 2 gearbox
- 3 crank arm bearing
- 4 connecting rod (plunger end)
- 5 connecting rod (crank end)
- 6 pick-up and auger drive shaft bearing (left)
- 7 wadboard idler sprocket
- 8A needle safety latch
- 8B knotter arm
- 9 needle yoke bearing (left)
- 10 to 26 knotter assembly
- 27 metering wheel
- 28 needle yoke bearing (right)
- 29 auger shaft bearing
- 30 auger tube bearing
- 31 pick-up and auger drive shaft bearing (right)
- 32 pick-up driven shaft bearing (right)
- 33 pick-up wheel
- 34 pick-up driven shaft bearing (left)
- 35 feeder plunger
- 36 plunger pin
- 37 P.T.O. drive pins (two drops of oil daily)
- 38 P.T.O. drive shaft universal
- 39 P.T.O. drive tube
- 40 front P.T.O. assembly (rear universal)
- 41 front P.T.O. assembly (front universal)

*E. P. oil is especially blended for use under extreme pressures and temperatures.

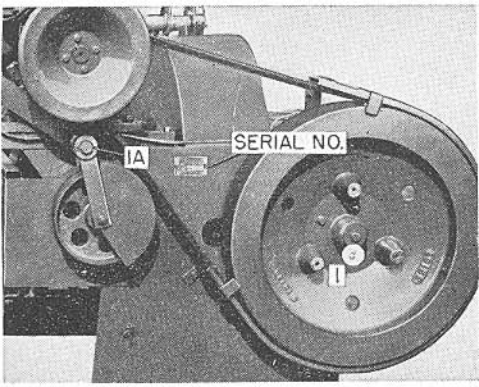

FIGURE 3A

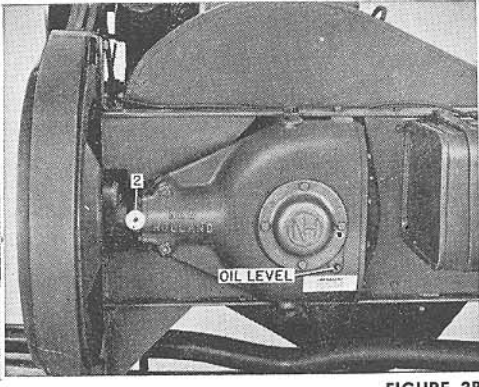

FIGURE 3B

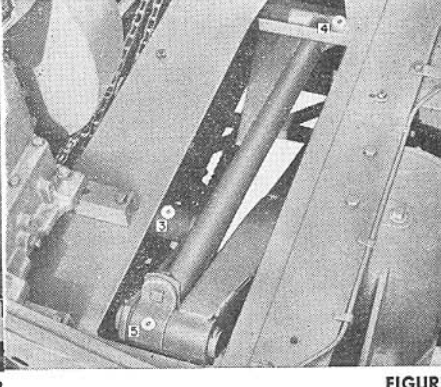

FIGURE 3C

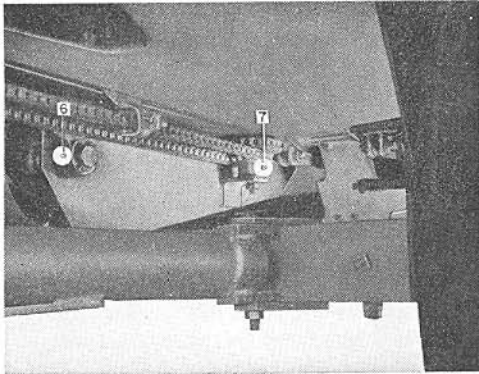

FIGURE 3D

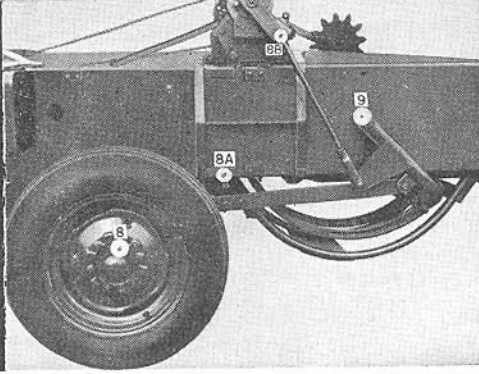

FIGURE 3E

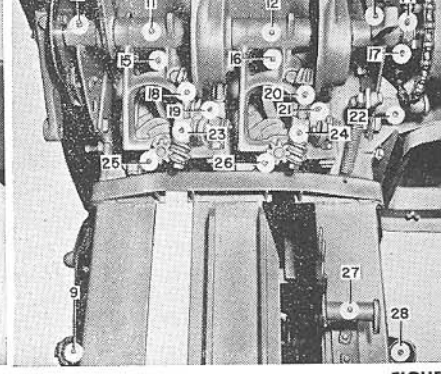

FIGURE 3F

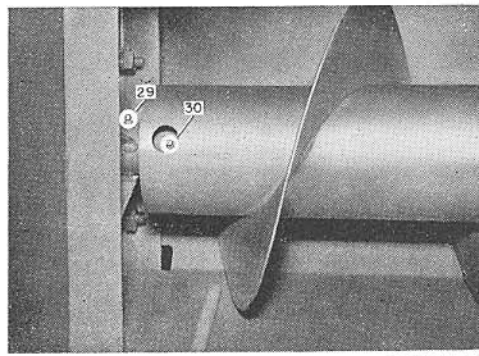

FIGURE 3G

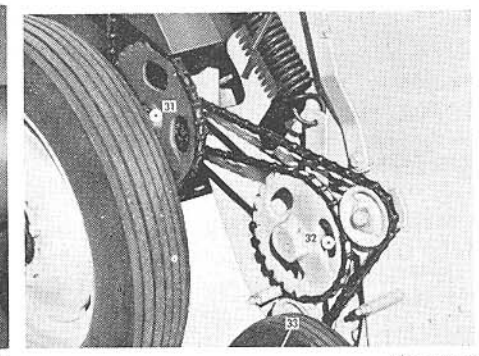

FIGURE 3H

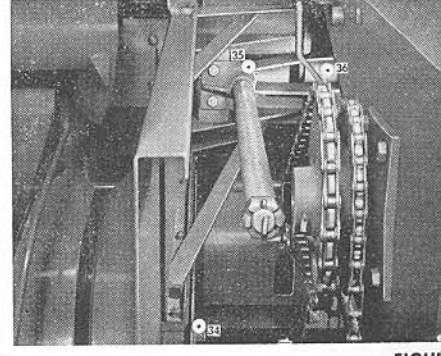

FIGURE 3I

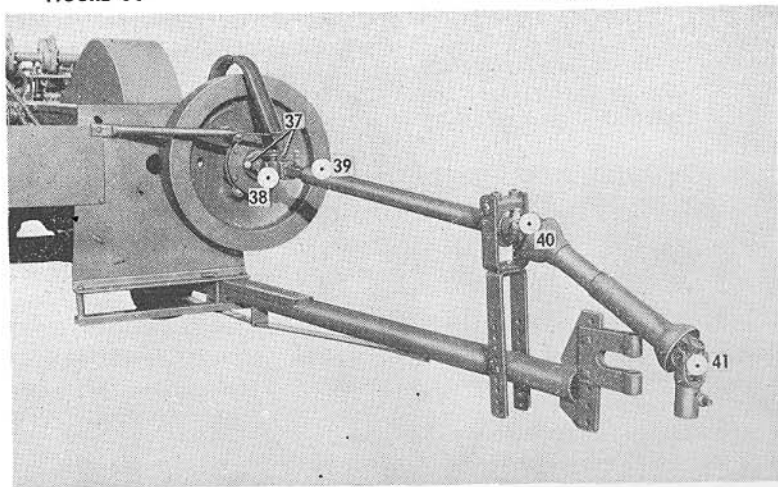

FIGURE 3J

Baler Break-In

Both the engine and the baler should be carefully serviced and "run in" before they are placed under load.

Before using the baler in the field, make sure that the machine is properly lubricated and turn the flywheel by hand to determine that all parts move freely.

Caution: Keep the shield over the main crank closed whenever the flywheel is in motion. Be sure that all persons and tools are clear of the baler before starting the engine.

The engine throttle has two speed positions. The first position is the fast idle speed for starting and warm up, and the second position is for full throttle setting for operation.

Set the throttle in the first notch and crank the engine by turning the crank wheel counter clockwise.

Allow the engine to run at this speed for several minutes to establish proper warm up and sufficient oil film on all moving parts.

Engage the belt tightener and operate the baler for 10 or 15 minutes, trip the knotter several times by turning the metering wheel.

Increase the engine speed to 2890 r.p.m. (70 plunger strokes of the baler) and allow the baler to run without load for at least 30 minutes. Refer to the engine manual if it is necessary to re-adjust the engine governor control linkage to obtain the correct number of plunger strokes per minute.

Note: Plunger speed should never exceed 70 strokes per minute; however, the baler can be operated to best advantage at somewhat slower speeds under some conditions.

For maximum life the engine should always be allowed to warm up before applying the load.

ATTACHING BALER TO TRACTOR

Attach the baler to the tractor so that the baler frame is as nearly level as possible. The hitch assembly of the baler can be adjusted up or down to accommodate various draw bar heights. In most cases the hitch should be 13 to 15 inches above the ground.

A straight type draw bar on the tractor (Fig. 4) is preferable to the "U" type draw bar for attaching the baler since shorter turns can be made with the straight draw bar. Attempting to use a "U" type draw bar without an adapter plate may result in damage to the baler hitch.

The tongue of the baler can be shifted from side to side. Swing the tongue to the extreme right, as illustrated, for road travel and move it to the extreme left when baling.

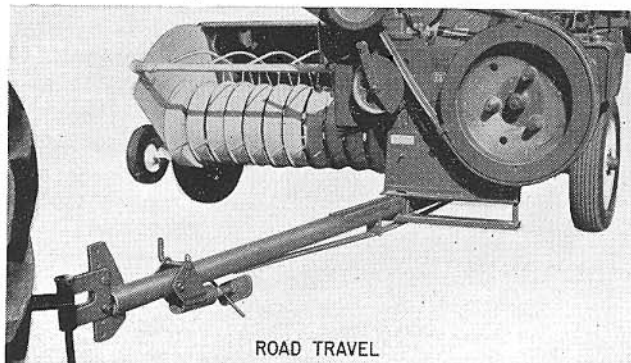

FIGURE 4

PREPARING TO BALE

Before attempting to tie material in the bale chamber, the operator should release all pressure on the tension rails by unscrewing the tension handles at the rear of the bale chamber as far as possible, and feed material through the machine until all rough paint and rust have been removed from the bale chamber.



FIGURE 5

THREADING NEEDLES

1. Place four balls of New Holland baler twine side by side in the twine box. Tie the two balls on each side of the partition together as shown. Be sure that the outside end of the twine of the left ball is tied to the center end of the right ball. Do not remove the wrappers from the twine, and be sure that they are placed in the box with the proper end up, as shown. Note: Pull the outside twine end of the left ball to the top of the paper jacket as illustrated. Be sure that the knots are tied securely and small enough to pass through the eye of the needle.
2. Start baling until the bale chamber is full of hay.
3. Thread the twine through the guides and needles, as shown. Be sure that the twine is placed under the spring loaded tension clips on the lid of the twine box (Fig. 6).
4. Tie the ends of the twine to the axle brace or the wagon hitch as shown in Fig. 6.
5. Continue to bale, and, as the hay turns the metering wheel, the knotter will start working automatically, bringing the needle through and threading the knotter.
6. Remove the ends of the twine that are tied to the axle brace before continuing to bale.

LENGTH OF BALE

Bale length is regulated by the metering wheel which is mounted on the bale chamber behind the knotter assembly. As compressed hay passes through the bale chamber, the metering wheel is turned by the hay and automatically trips the knotters during each revolution.

The metering wheel can be adjusted to meter any length bale desired from 12 to 52". Refer to Page 17 for details on metering wheel adjustment.



REGULATING BALE WEIGHT

The adjustment of the spring loaded tension bolts on the back end of the baler regulates the density and the weight of the bales by controlling the pressure of the tension rails on the material passing through the bale chamber. The correct adjustment of the tension rails is determined by the tightness of the twine on the finished bales and the weight of the bales themselves. Turn the tension bolt handles approximately half way down on the threads of the spring loaded tension bolts before beginning to bale. After baling several bales, check bale weight and compactness. To increase the bale weight, turn the tension bolt handles one or two turns clockwise and continue to bale. If further adjustment is needed after baling three or four bales, repeat the above procedure until the proper adjustment is obtained.

Bale weight is decreased by turning the tension bolt handles in a counter-clockwise direction.

Although the springs on the tension bolts compensate for some variation in moisture content of the material being baled, it may be necessary to re-adjust the tension from time to time when the moisture content of the hay varies greatly in different parts of the field. Experience will teach the operator the correct tension bolt handle adjustment required for particular conditions. Caution: Attempting to bale too tight may cause the twine to be pulled from the twine disc of the knotter with untied bales as a result.

TYING

FIGURE

The knotters are adjusted at the factory and should need little or no further adjustment. If, however, either knotters should miss tying a few bales when first starting to bale, do not tamper with it but allow it to wear a little. The action of the twine upon the knotter parts will smooth any roughness produced by painting.

Experience has shown that a large percentage of knotter difficulties is the result of baling with excessive bale tension. Therefore, before making any knotter adjustments be certain that excessive bale tension is not the cause of the knotter difficulty. It is advisable also to check the setting of the needles and the twine fingers and eliminate excess vertical plunger clearance before changing knotter adjustments.

A firm tension on the twine produces best results. Adjust the twine tension by loosening or tightening bolts "A" and "B", Fig. 6, on the lid of the twine box.

Do not attempt to regulate the size or density of the bales with the tension on the twine box, or by adjusting the knotter springs.

Should it become apparent that the tying difficulty is not due to rough edges on the knotter or the bale chamber, but rather to mis-adjustment, study the section on knotter adjustment carefully before attempting to correct the difficulty.

SAFETY FEATURES

NEEDLE SAFETY LATCH

The needles are protected against breakage by a needle safety latch which moves in front of the plunger whenever the needles enter the bale chamber.

If, for any reason, the needles should remain in the bale chamber when the plunger returns with a new charge of hay, the plunger is stopped by the safety latch and the flywheel safety bolt is sheared.

Adjust the needle safety latch so that it is pulled completely out of the bale chamber when the needle yoke is at rest but always make certain that the latch remains in the path of the plunger until the tips of the needles are entirely withdrawn from the bale chamber.

Secure the proper safety latch adjustment by moving the slotted safety latch ejector bracket which is mounted on the needle yoke arm (point A, Fig. 7).

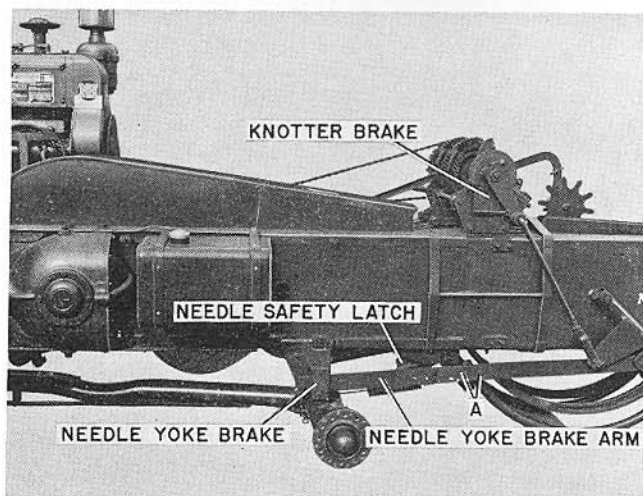

FIGURE 7

Should the action of the needle safety latch cause the shearing of the flywheel shear bolt, remove the hay from between the plunger and the needles and correct the difficulty which caused the needles to remain in the bale chamber. Return the needles to their home position by pulling back on the needle yoke and place the knotter stop in front of the knotter clutch pawl before replacing the shear bolt and starting the machine. Otherwise the plunger will again contact the needle safety latch and will again shear the flywheel safety bolt.

SHEAR BOLTS

The Model 66 baler is protected at three points by safety shear bolts: One $\frac{3}{8}$ " x $2\frac{3}{4}$ " special machine bolt in the flywheel; one $\frac{5}{16}$ " x 2" machine bolt in the knotter drive sprocket; and two $\frac{3}{16}$ " x $1\frac{1}{4}$ " stove bolts at the point where the plunger arm is connected to the wadboard drive chain (Figure 8C).

THE FLYWHEEL SHEAR BOLT IS A SPECIAL ANNEALED BOLT OF SPECIFIC HARDNESS SUPPLIED BY NEW HOLLAND AND IT CAN BE READILY IDENTIFIED BY ITS COPPER PLATING. DO NOT USE SUBSTITUTES.

The knotter drive shear bolt is a common soft machine bolt and the wadboard shear bolts are common stove bolts. **Never install larger bolts or cap screws of higher strength steel. Use only bolts of the specified size and strength.**

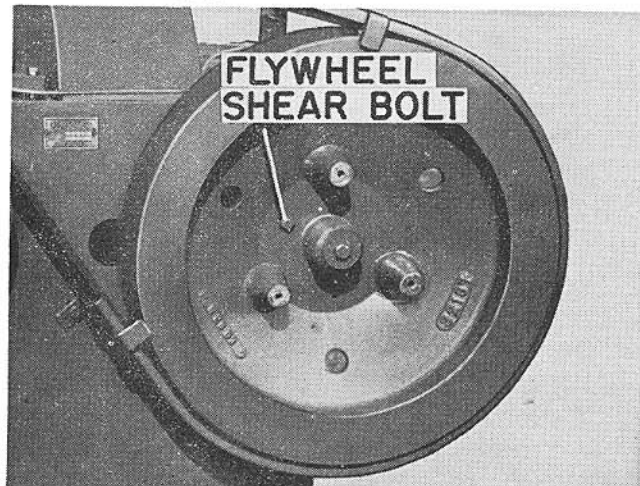

FIGURE 8A

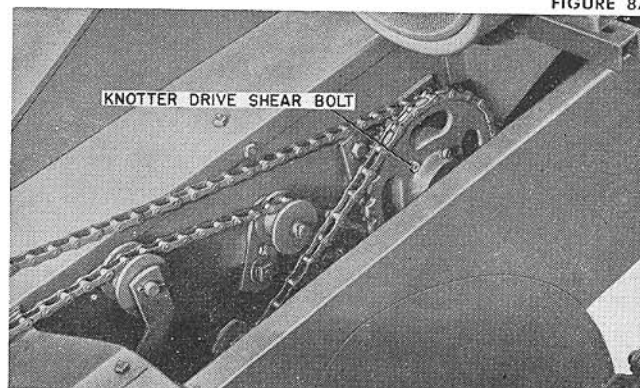

FIGURE 8B

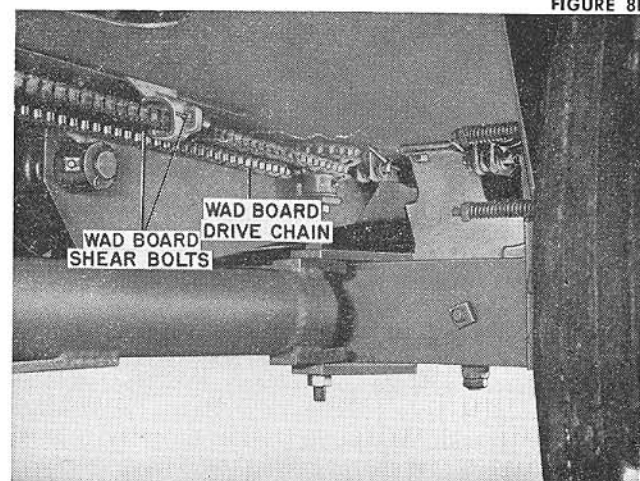

FIGURE 8C

Always determine and correct the cause of shear bolt failure before continuing to operate the machine.

Caution: If the flywheel shear bolt fails during the tying cycle and the needles are in the bale chamber, clean the hay from between the needles and the wadboard and return the needles to their home position before attempting to continue to operate the machine. Refer to the section on the needle safety latch, page 12 for further details.

PICK-UP SLIP CLUTCH

The pickup slip clutch when properly adjusted regulates the feed of the crop into the machine, and prevents overloading or damage to the feed mechanism.

For average conditions the clutch springs should be compressed to a minimum length of 1-7/16 inches. When the clutch facings wear it will be necessary to adjust the compression length of these springs, when adjusting keep the spring length uniform.

Insufficient tension will be detected by loss of baling capacity.

Excessive tension will cause constant shearing of the flywheel safety bolts, and place undue strain on the feed mechanism.

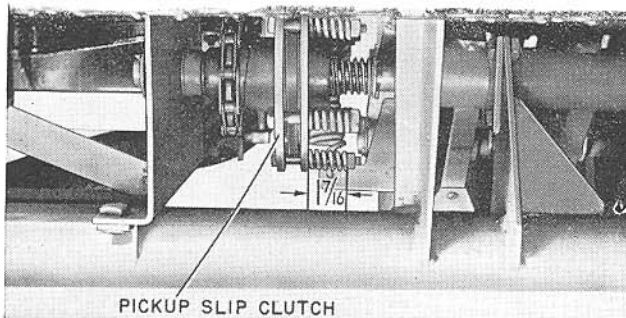

FIGURE 9

WIND GUARD

Adjust the wind guard rods of the pick-up to accommodate size of windrow and condition of material, by rotating the wind guard stop (Figure 10) so that material is held firmly against the pick-up fingers. Increase the tension on the rods by tightening the coil spring on the supporting bar across the front of the pick-up.

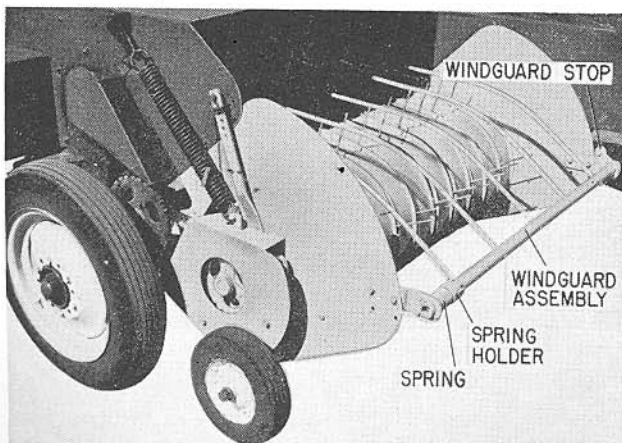

FIGURE 10

PICK-UP LIFT SPRING

The pick-up is provided with a lift spring that is designed to give the pick-up a "floating action". The AUXILIARY PICK-UP WHEEL SHOULD STRIKE THE GROUND ONLY OCCASIONALLY and guide the pick-up over rough and uneven ground. At no time should the pick-up wheel carry the entire weight of the pick-up.

To avoid undue strain on the pick-up assembly and the pick-up ground wheel, adjust the pick-up lift spring by tightening the nut on the lift spring tension bolt until the pick-up wheel rests lightly on the ground.

Secure the proper clearance between the pick-up fingers and the ground by bolting the mounting bracket of the pick-up wheel to the channel iron support through the appropriate hole.

Lock the pick-up in the raised position for road travel by inserting the lock pin behind the pick-up lift lever at the side of the pick-up as illustrated below.

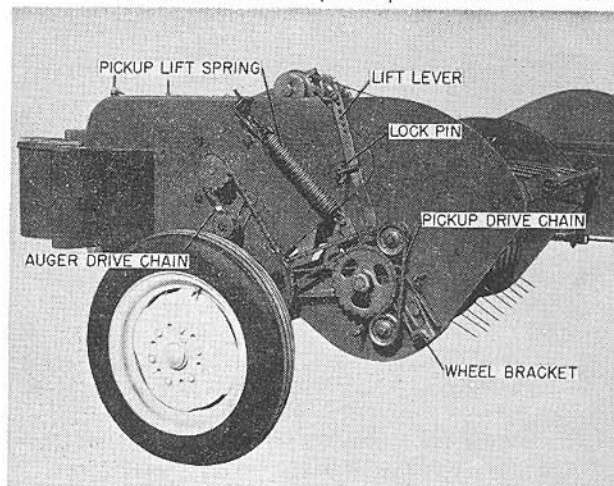

FIGURE 11

PICK-UP CHAINS

Install the pick-up drive chain and the auger drive chain as shown above. Keep these chains moderate tight and lubricate them frequently with light machine oil.

KNOTTER BRAKES

The brake on the knotter disc and the brake on the needle yoke arm (Fig. 7), are designed to insure smooth action of the knotter and prevent drifting of the needle yoke when the knotter clutch is dis-engaged.

The tension springs of the brakes should be adjusted periodically to compensate for slight wear of the brake linings. Check the tension springs on the needle yoke arm brake periodically and maintain a compression length of 2 3/8". Tighten the spring on the knotter disc brake only to the point where backlash is removed from the knotter assembly.

If the needle yoke brake becomes too loose, the needle yoke may drift forward and allow the needle safety latch to enter the bale chamber and cause the flywheel safety bolt to be sheared.

Keep braking surfaces free of paint, rust, grease and oil. Replace worn linings promptly.

ADJUSTMENT

MOUNTING NEEDLES

When installing one or both needles proceed as follows:

Set the needles in the approximate position on the needle yoke and tighten the mounting bolts slightly. Note: Insert the mounting bolts as shown in Fig. 12 with the rear bolt from the top down and the front bolt from the bottom up.

Release the knotter clutch by pulling the knotter stop from in front of the knotter clutch pawl. Pull forward on the needle yoke to bring the needles through the bale chamber and move the needles sideways until they rub lightly against the knotter frame. Adjust the needle mounting bolts so that the tips of the needles clear the twine disc and the twine holder by not more than $\frac{1}{8}$ " (Fig. 13).

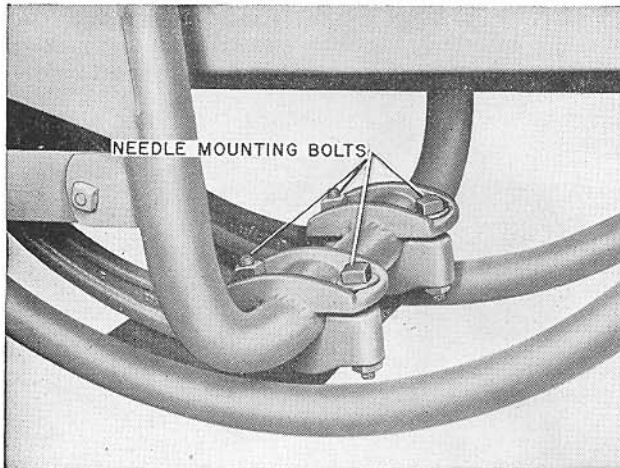

FIGURE 12

To secure more clearance between the needle and the twine disc, loosen the front needle mounting bolt slightly and tighten the rear bolt. Loosening the rear mounting bolt and tightening the front bolt draws the needle closer to the twine disc.

After the needles are adjusted properly, tighten all bolts securely and re-check the needle setting.

Return the needles to their home position and set the knotter stop in front of the knotter clutch pawl.

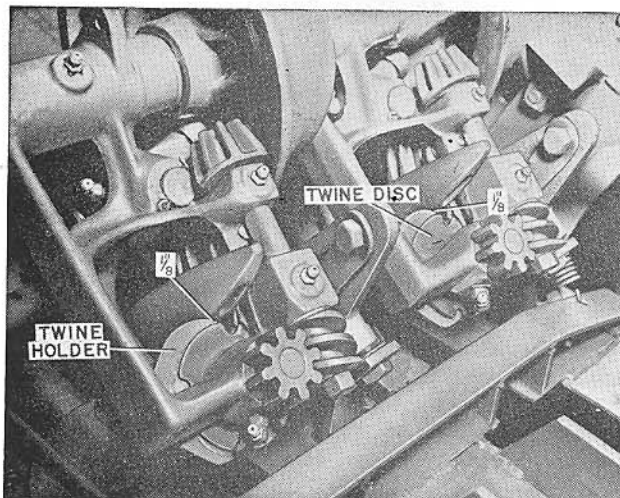

FIGURE 13

NEEDLE YOKE

When the needles are all the way through the bale chamber (the knotter arm on dead center) there should be at least $\frac{1}{8}$ " and not more than $\frac{3}{4}$ " clearance between the bottom of the bale chamber and the needle yoke.

To secure the proper needle yoke clearance, remove the needle yoke rod from the knotter arm, loosen the jam nut "B", Fig. 14, and turn the rod as required. Re-install the needle yoke rod and turn the knotter through a complete cycle to make sure that the needle yoke does not strike the bale chamber.

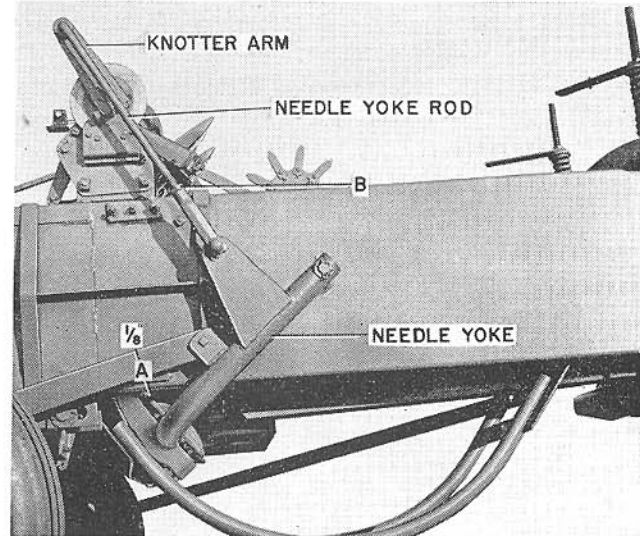

FIGURE 14

NEEDLE TIMING

Needles, when properly "in time" with the plunger, just begin to enter the bale chamber when the tips of the projections on the face of the plunger have passed the points of the needles by $\frac{1}{4}$ " - $\frac{3}{4}$ ".

If, for any reason, the needles should require "timing" follow this procedure:

1. Remove the knotter drive chain.
2. Turn the flywheel counter-clockwise until the crank is in a vertical position between the timing marks, "A" and "B" (Fig. 15), on the upper side of the bale chamber.

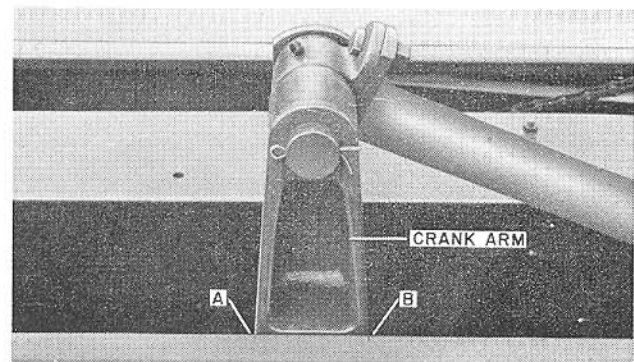

FIGURE 15

3. Make certain that the knotter clutch pawl is resting against the knotter stop and remove the backlash in knotter clutch by pulling upward on the needle yoke rod at the point where it is attached to the knotter arm.

ADJUSTMENT

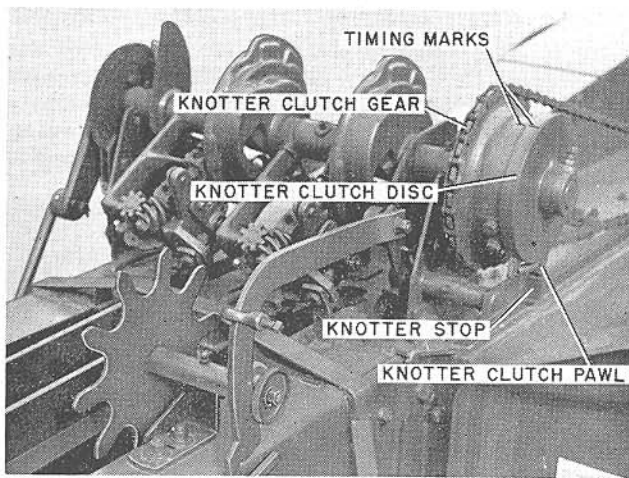

FIGURE 16

4. Turn the knotter clutch gear until the timing marks of the knotter clutch and the knotter clutch disc are directly opposite each other as shown (Point A, Fig. 16).
5. Install the knotter drive chain, position the chain tighteners, and tighten the drive chain securely, keeping the timing marks on the knotter clutch gear and the knotter clutch disc directly opposite each other.
6. Engage the knotter clutch and turn the knotters through a complete cycle to make sure that the needles enter the plunger slots at the proper moment. **Keep the knotter drive chain tight at all times to maintain the proper needle timing.**

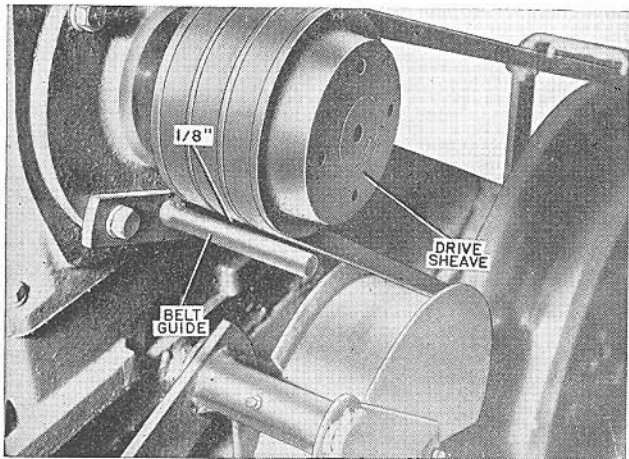

FIGURE 16A

DRIVE BELTS

New "V" belts may tend to drag on the flywheel until they wear slightly. The drive belts will also tend to drag on the flywheel when the belt tightener is released if the belt guide under the drive sheave of the engine is not installed properly. Adjust the belt guide so that the belts just clear the guide when the belt tightener is engaged as shown above. Adjust the "V" drive belts as stretch develops by mounting the tightener latch in a lower position. Further adjustment can be made by loosening the four mounting bolts of the engine and sliding it sideways away from the flywheel.

WADBOARD TIMING

Positive feeding of material into the bale chamber is accomplished by the wadboard which moves the bale chamber between plunger strokes and places a charge of hay in front of the plunger.

Correct wadboard timing is essential in maintaining proper clearance between the wadboard and plunger. Time the wadboard as follows:

Turn the flywheel until the plunger is in its extreme position toward the front of the baler. Loosen the wadboard drive chain enough that the chain can be slipped on the sprocket and set the wadboard so that it extends into the bale chamber with approximately 3½ inches between the end of the wadboard and the left side of the bale chamber.

Install and tighten the wadboard drive chain. Turn the baler manually to make certain that the wadboard has proper clearance at each end of its stroke.

Wadboard penetration may be regulated to some degree if too much material is placed on one side of the finished bale, by loosening the wadboard drive chain and jumping teeth on the drive sprocket or attaching the wadboard arm to another connector link of the wadboard driven chain (#32286) under the flywheel. Make sure that the wadboard has proper clearance at each end of its stroke before operating the machine.

WADBOARD ADJUSTMENT

The wadboard is provided with a lower adjusting slide to take up clearance between the wadboard and the slides caused by wear.

For maximum life of the wadboard it is essential that the vertical movement between the slides and wadboard be held to 1/16". This adjustment should be made after the first 500 bales, and checked periodically thereafter.

When operating in extremely sandy soil conditions it may be necessary to adjust daily.

Under no circumstances should the wadboard slides be lubricated.

Adjustment is accomplished by loosening the mounting bolts, and using the adjusting bolts (Fig. 17), found on either end of the slide. Keep the lower slide parallel to the upper slide. When adjustment is complete be certain the wadboard moves freely, within the slides throughout its travel range.

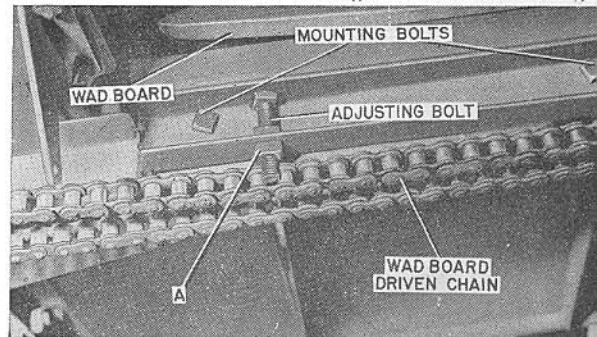

FIGURE 17

Note: Re-adjustment of the wadboard slides may be necessary to compensate for wadboard variations due to moisture or extreme differences of humidity. **Always make sure that the wadboard moves freely before operating the baler.**

ADJUSTMENT

KNIFE ADJUSTMENT

The knives mounted on the plunger and the side of the bale chamber should be kept sharp and properly adjusted. The knife mounted on the side of the plunger should clear the stationary knife by approx. $1/32''$ of an inch. Frequently remove the stationary knife from the baler and sharpen, maintaining the original angle as nearly as possible. When re-mounting the knife, make sure that it is properly seated, and securely tighten the mounting bolts.

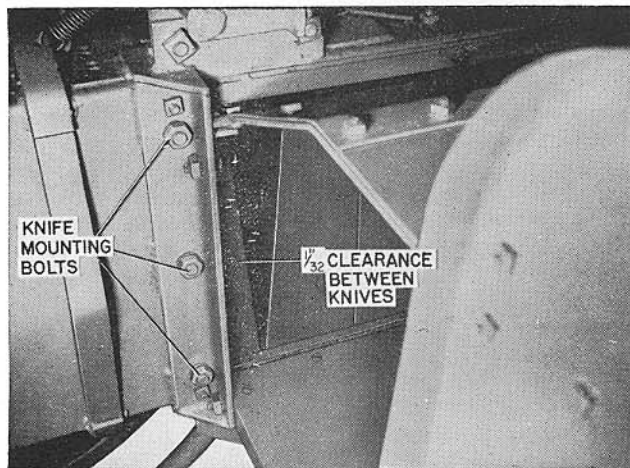

FIGURE 18

As the wooden slides become worn, the knife clearance increases. To secure proper knife clearance, move the plunger to the end of its compression stroke and adjust the plunger slide rails on the left side of the bale chamber by loosening the twelve mounting bolts of the upper and lower slide rails and tightening the set screws which move the plunger slide angles inward. (Fig. 19). Re-tighten the mounting bolts and the adjusting bolts firmly when the desired adjustment is obtained and excess side play is removed from the plunger.

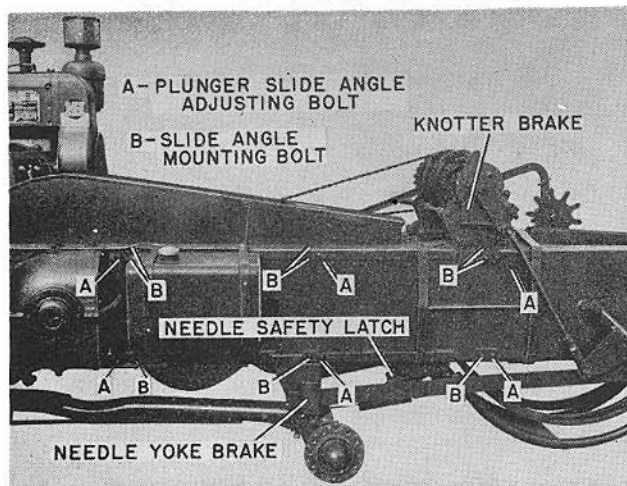

FIGURE 19

PLUNGER SLIDE and FEEDER PLUNGER ADJUSTMENT

It is important that the vertical clearance of the main plunger be kept at a minimum. Excess clearance between the top of the plunger and the top of the bale chamber may result in tying problems that are caused by the baled material interfering with the twine as it is placed in the knotters.

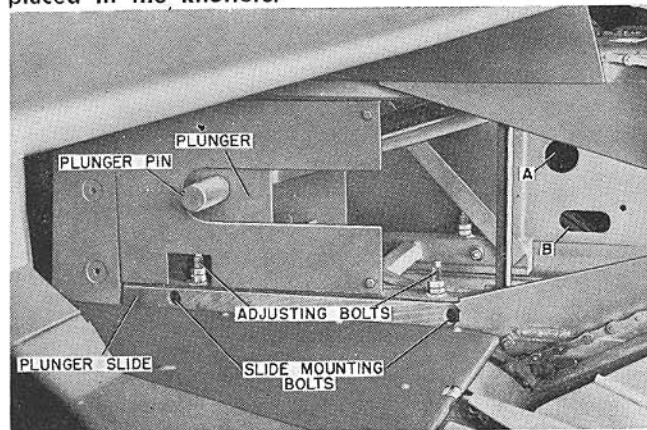

FIGURE 20

Remove excess vertical play from the main plunger and the feeder plunger assembly as follows:

1. Loosen the mounting bolts of the feeder plunger connecting rod bearing (point A, Fig. 21).
2. Loosen the four mounting bolts of the lower slides of the main plunger (see Fig. 20). Tighten the four plunger slide adjusting bolts to the point at which the plunger has a vertical clearance of $1/32''$.
3. Loosen the bolts of the lower slide track of the feeder plunger guide assembly (Fig. 21) and move the slide track upward until the feeder plunger has a vertical clearance of $1/32''$.
4. With the plunger on front dead center, move the feeder plunger connecting rod bearing up or down until the spring loaded feeder plunger connecting rod is parallel with the feeder plunger slide tracks. Tighten all bolts securely.
5. Reinstall the wadboard shear bolts (Figure 8C) in the holes in the plunger arm which allow the wadboard drive chain to be most nearly aligned.
6. Turn the flywheel to check the action of the plunger and the feeder plunger. Make sure that these parts move freely.

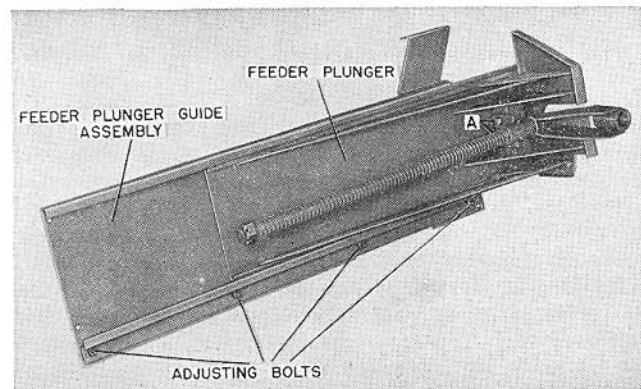

FIGURE 21

REPLACING PLUNGER SLIDES

Check the plunger slides periodically for wear and readjust if the plunger has more than $\frac{1}{8}$ " vertical play. When further adjustment is impossible, remove the feeder plunger assembly and the main plunger from the baler and install a complete new set of slides.

To remove the feeder plunger:

1. Disconnect the pick-up lift lever (Fig. 11) and raise the baler tongue until the left side of the pick-up is lower than the feeder plunger guide assembly.
2. With the feeder plunger at the front end of its stroke, remove the five mounting bolts from the feeder plunger guide and remove the entire feeder plunger assembly from the machine.

Note When reinstalling the feeder plunger make sure that the feeder plunger slides are exactly parallel with the right side of the bale chamber before tightening the mounting bolts of the feeder plunger guide support plate at the front end of the baler.

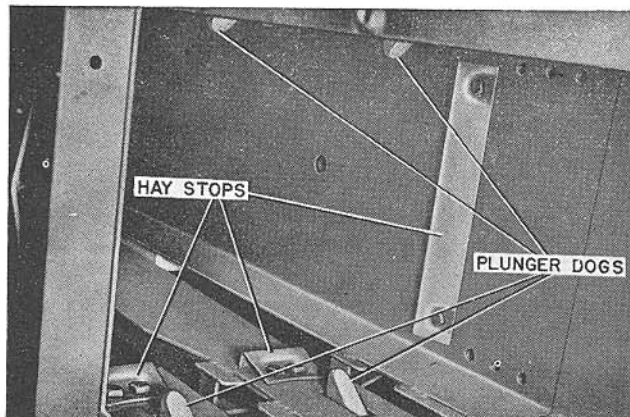

FIGURE 21A

Remove the main plunger as follows:

1. Remove the feeder plunger assembly as instructed above.
2. Loosen the set screws in the plunger pin bearings, and position the plunger so that the plunger pin can be driven through hole "A" (Figure 20) provided in the side of the bale chamber. Drive the plunger pin from the plunger with a soft punch. Note: If the plunger pin does not move readily, remove the set screws from the plunger pin bearings and apply penetrating oil at these points.
3. Remove the wedge shaped hay stops that are bolted to the inside of the bale chamber and block the spring loaded hay dogs out of the bale chamber.
4. Slide the plunger out of the back of the bale chamber.

METERING WHEEL

The metering wheel, which regulates the length of the finished bale, is mounted on the upper side of the bale chamber. As compressed hay passes through the bale chamber, the metering wheel is turned by the hay and automatically trips the knotter.

The metering wheel is designed to meter accurate length bales and can be adjusted to produce bales from 12" to 52" in length. Each time a bale is metered the trip mechanism is zeroed for the start of the next bale, thus keeping the variation in length to the very minimum.

Figure 22 shows the metering wheel with the trip arm stop set to meter the shortest or 12" bale.

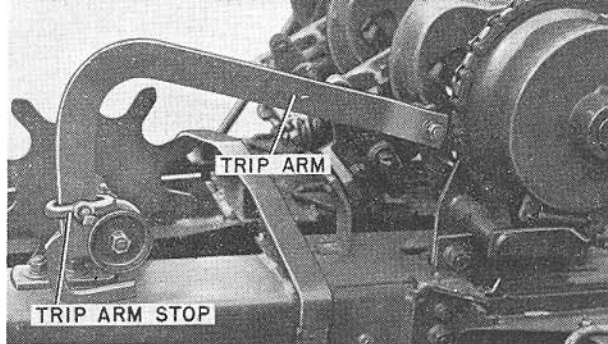

FIGURE 22A

Figure 22A shows the metering wheel with the trip arm stop set to meter the longest or 52" bale.

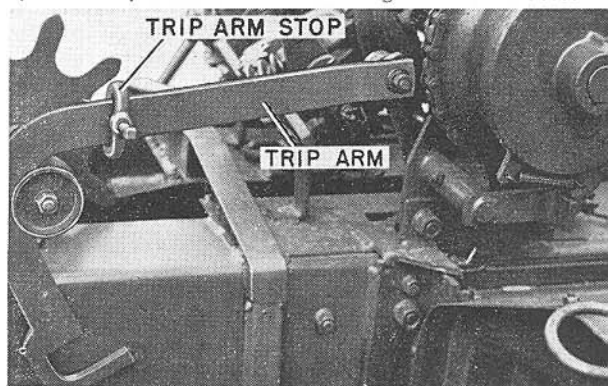

FIGURE 22B

Any bale length desired between these two ranges can be secured by positioning the trip arm stop between these maximum and minimum positions. Measure the metered bales and adjust the trip arm stop to the position required to give the desired bale length.

ADJUSTMENT

Rotate the knotter assembly until the cam follower on the knotter cam gear has moved trip arm to the rearmost position. Loosen the bolts holding the metering wheel bracket to the bale chamber and adjust the metering wheel assembly so that there is $\frac{1}{8}$ " clearance between the friction disc and the front edge of trip arm. Point A, Figure 22B.

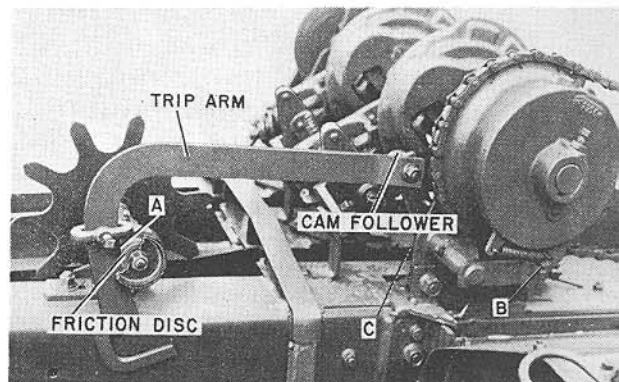

FIGURE 22C

Replace friction disc when worn and slippage is noted. Keep roller free of grease and dirt. The front edge of the trip bracket which contacts the friction disc should be smooth and free of grease or oil.

Rotate the knotter assembly until it is in its home position. Position knotter stop squarely in front of knotter clutch pawl, Point B, Fig. 22B. To make this adjustment loosen nut at point C.

KNOTTER ADJUSTMENT

Any adjustment of the knotter assemblies should be made carefully at a single point and generally not more than a quarter of a turn at a time. Before making further adjustment, check the performance of the knotter for four or five bales.

In any case, it is not advisable to mutilate the knotter in any way.

TWINE FINGERS

It is the function of the twine fingers to pick up the twine brought to the knotters by the needles and place and hold it in the proper position for the bill hooks.

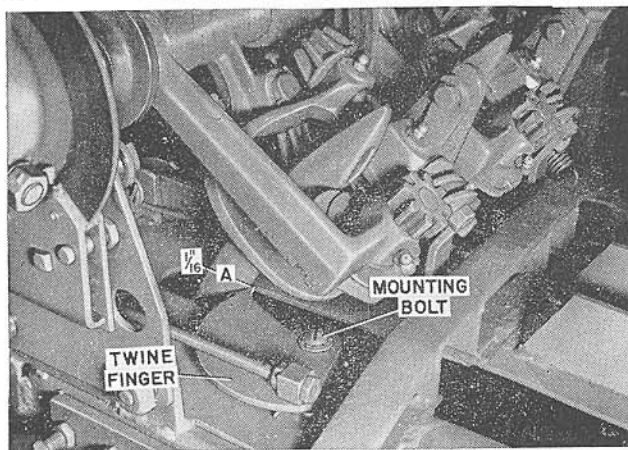

FIGURE 23

The importance of proper twine finger setting cannot be over-emphasized since a large percentage of all tying failures is due to their mis-adjustment.

To adjust the twine fingers proceed as follows:

1. Check the needle setting and make sure that the needles are properly adjusted as outlined on page 14.
2. Trip the knotters and manually turn the flywheel counter-clockwise until the tips of the twine fingers begin to pass the needles.

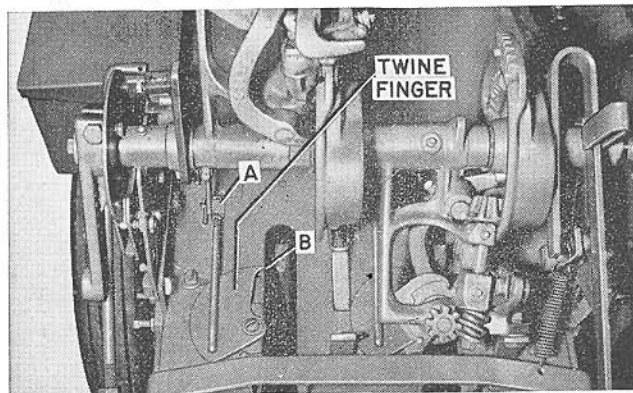

FIGURE 24

3. The twine fingers should clear the needles by not more than 1/16". (point A, Fig. 23). Secure proper twine finger clearance by loosening the twine finger mounting bolts and moving them forward or backward in the slots in which they are installed.

4. Turn the knotters through their complete tying cycle and check the position of the twine fingers at rest. Adjust the twine finger linkage (point A, Fig. 24) so that the tip of the twine finger rests at the edge of the needle slot of the bale chamber as illustrated (point B).

Re-check the twine finger action to make certain that the twine fingers are not activated before the needles place the twine in front of them. Also make sure that the plunger slides are properly adjusted (See Page 16) to eliminate the possibility of stubbles keeping the twine from being placed in front of the twine fingers.

TWINE DISC

The twine disc setting is determined by the positioning of the notch in the disc to the twine holder (point A, Fig. 26). The top of the notch should be flush with the bottom of the twine holder (when the disc contains twine). If the twine disc is advanced too far the twine will not be caught in the twine disc.

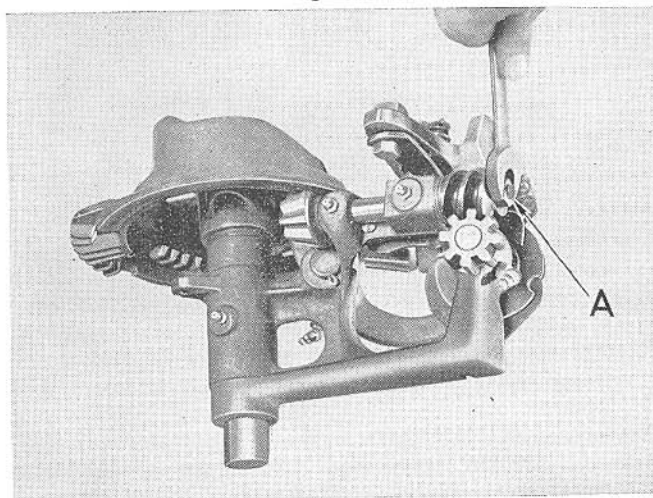

FIGURE 25

In order to adjust the disc to this position, loosen nut "A" several turns as shown in Fig. 25. Tap the nut end of the shaft and turn the disc to the setting of the notch shown in Fig. 26.

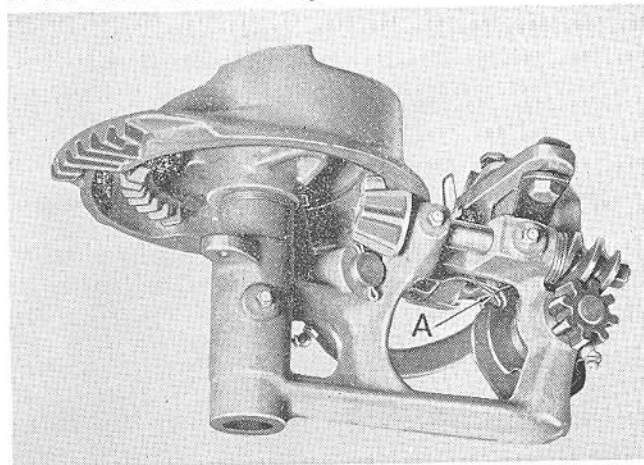

FIGURE 26

KNOTTER ADJUSTMENT

After the twine disc is positioned properly, tap the pinion end of the shaft to move it back to its original position. Turn the worm gear so that it will fit against the spacer washers; then turn the lock nut tight.

CAUTION: Be sure the spacer washers at point "A" do not catch on the shoulder as noted in Fig. 27.

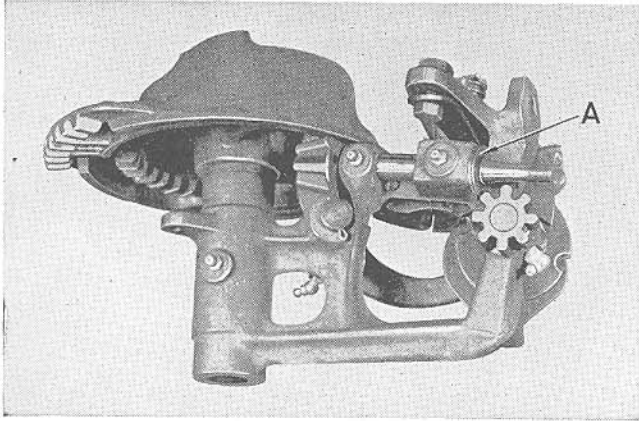

FIGURE 27

TWINE HOLDER

The twine holder "A" Fig. 28 is a double plate which holds the twine in the twine disc. The holder is retained in position by a flat spring "B" with adjustable tension screw "C". The twine holder tension spring exerts pressure against the twine holder, which in turn holds the twine in the disc under pressure.

The tension spring must be adjusted according to the weight and density of the bales that are produced. When the weight of the bale is increased, the adjusting screw on the twine holder tension spring must be adjusted accordingly. The reverse adjustment should be made when the weight is reduced.

It will often be found that in moving from one field to another, the tension on the twine holder must be changed because of the variation in the moisture content of different types of hay.

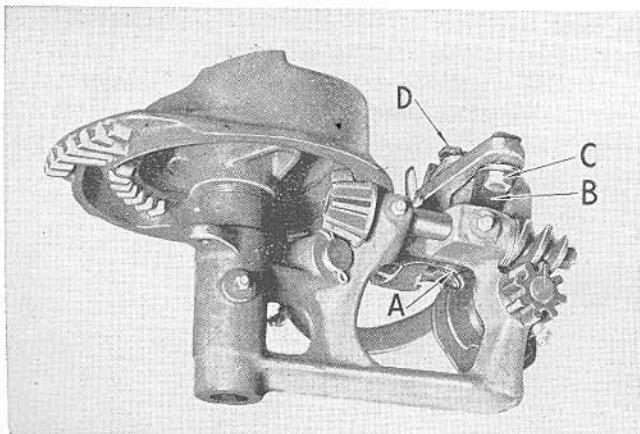

FIGURE 28

BILL HOOK

Proper adjustment of the bill hook is very important because it is here that knots are formed.

If for any reason the bill hook tongue is bent there is a possibility that the bill hook may not catch both strands of twine. The back of the tongue should be straight, not curved. Rough edges and fins on all parts of the bill hook will cause the knots to cling to the bill hook. All these rough edges should be removed with a file, then thoroughly smoothed with emery cloth.

Knots may hang on the bill hook because of excessive tension on the bill hook cam. If this occurs, some of the tension should be relieved by loosening the bill hook adjusting screw "D" (Fig. 28), slightly.

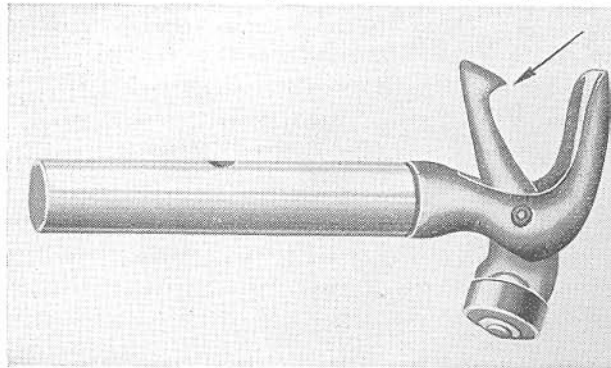

FIGURE 29

If the knot opens after it has been tied or if it is very loose and can be pulled open, it is possible that the bill hook does not close tightly enough to hold the ends of the twine securely between the bill hook tongue and the bill hook jaw until the knife or stripper flange strips the loops over the ends of the twine. The difficulty is caused by the sharp end of the bill hook tongue (Fig. 29). To correct this, file the sharp end slightly until the tongue is rounded as shown in Fig. 30.

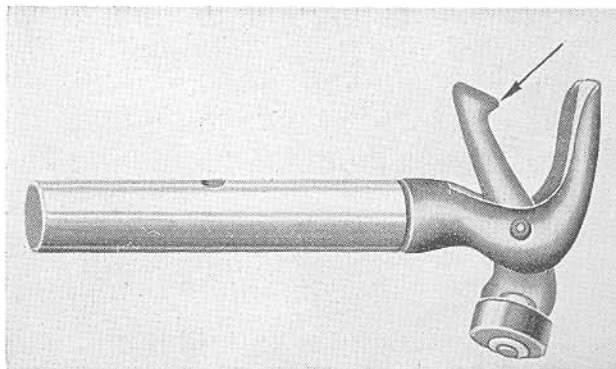

FIGURE 30

KNOTTER ADJUSTMENT

Figure 31 shows a closed bill hook with the proper amount of space between the bill hook jaw and bill hook tongue. A bill hook of this type will hold the ends of twine securely while the loop is drawn tight over the ends of the twine to form a good knot.

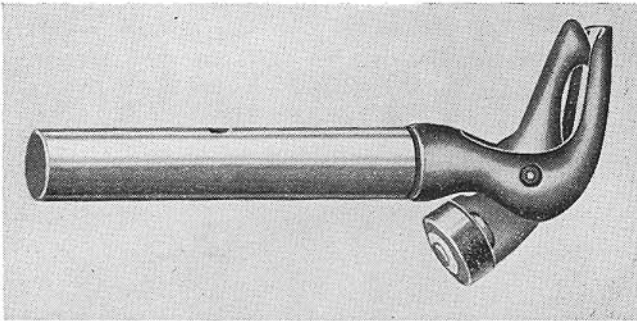

FIGURE 31

KNIFE ARM

The knife arm should be adjusted so that the bill hook will revolve without contacting any surface of the knife arm assembly as shown in Fig. 32.

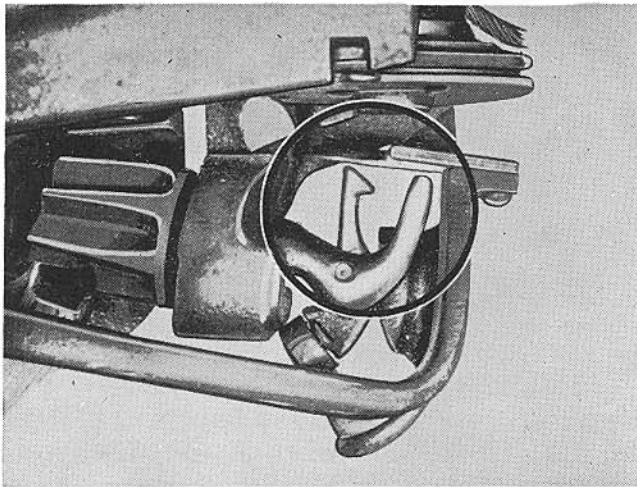

FIGURE 32

The half-moon shaped knife arm stripper flange should rub against the heel of the bill hook when the knife arm lowers as illustrated at point "A" Fig. 33. When set in this position, this flange will push the knot

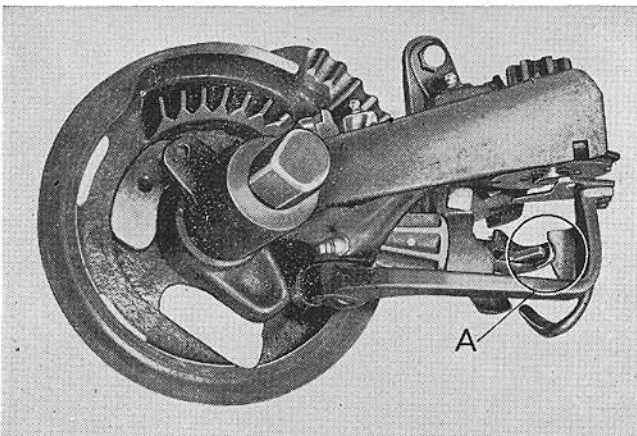

FIGURE 33

loop off the bill hook while the bill hook jaw holds the two ends, and a good knot will be formed.

When the half-moon shaped stripper flange does not rub against the bill hook heel it will pass by the twine as shown in Fig. 34, and, as a result, the knot will not be removed from the bill hook.

Knots may also hang on the bill hook if the knife arm has insufficient lift. When adjusted properly, the stripper flange of the knife arm will clear the end of the bill hook by not less than $\frac{3}{8}$ " and not more than $\frac{1}{2}$ ".

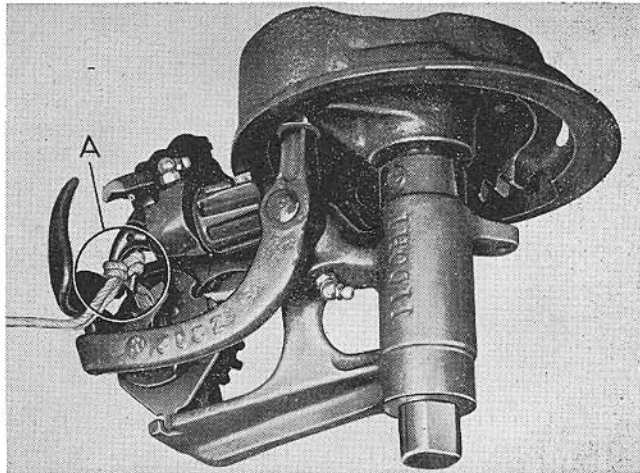

FIGURE 34

To determine when knife arm adjustment is necessary, trip the knoter mechanism and turn the flywheel manually to run the knoter one complete cycle. By watching the knife arm operation, see if any of the above mentioned knife arm maladjustments can be noted. If maladjustments are noticed, or if there is any reasonable doubt, remove the knoter mounting bolt and swing the knoter assembly out from its regular position. By so doing this, a closer inspection can be made of the knife arm setting.

If it appears that a slight knife arm adjustment is necessary, it may be possible to bend the knife arm with a hammer or pry bar without removing any parts of the knoter.

When considerable adjustment is necessary it is advisable to remove the knife arm assembly and bend it by using a wide-jawed vice. The knife arm assembly can most easily be removed by first removing the bill hook adjusting cam and the bill hook.

Figure 35 shows the type of knot formed by a properly adjusted knoter.

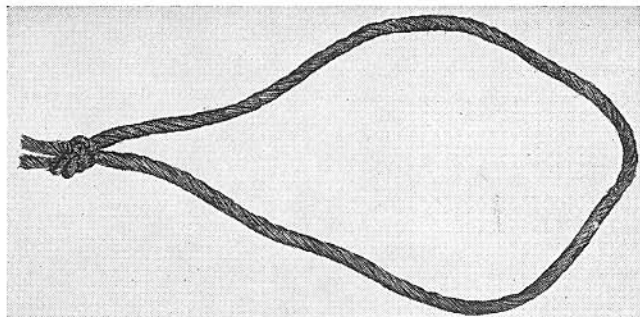
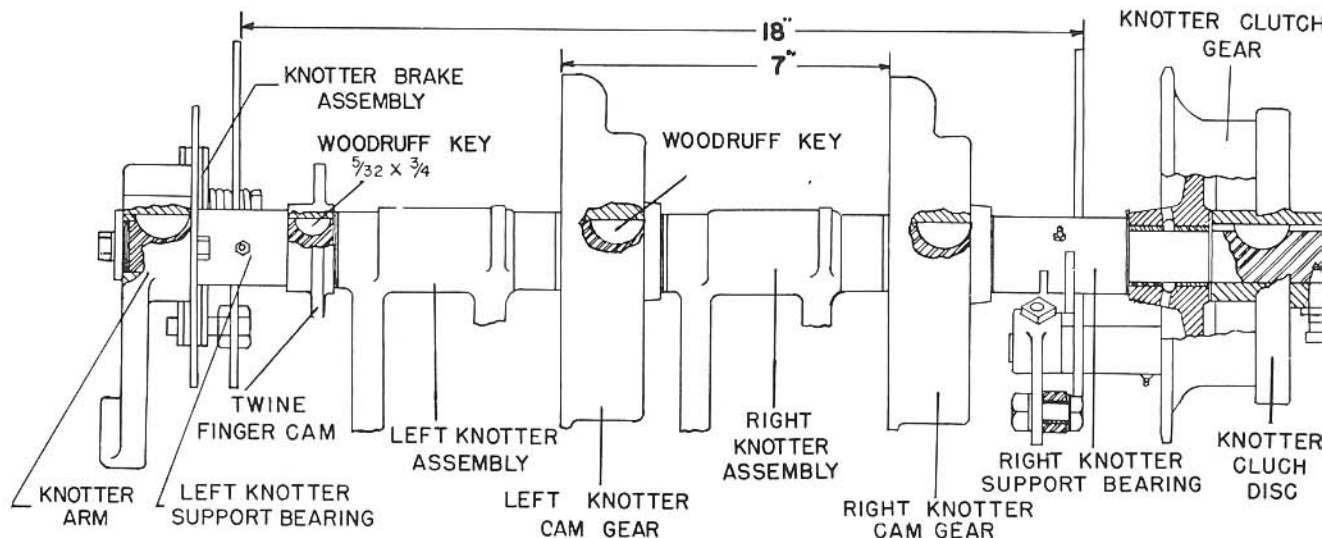

FIGURE 35

KNOTTER ASSEMBLY



FIGURE

KNOTTER SHAFT ASSEMBLY

1. Examine the knotter shaft for straightness and check the wear of the keyways before replacing any parts on the shaft.
2. Install the knotter clutch disc assembly with the woodruff key in place.
3. Use a $\frac{1}{32}$ " space washer and install the knotter clutch gear.
4. Use a $\frac{1}{32}$ " space washer and place the knotter support bearing #29546 on the shaft.
5. Place a $\frac{1}{32}$ " washer next to the support bearing, install a $\frac{1}{4} \times \frac{1}{8}$ " woodruff key, and position the knotter cam gear, making sure that it is seated properly.
6. Use a $\frac{1}{8}$ " space washer and install the right knotter assembly. Examine the knotter pinion gear to make sure that the flat of the pinion gear rests against the flat of the knotter cam gear with no more than $\frac{1}{32}$ " clearance.
7. Install a $\frac{1}{32}$ " washer and a $\frac{1}{16}$ " washer. Insert the woodruff key and place the left knotter cam gear on the shaft. Check the distance between the machined surfaces of the knotter cam gears and make certain that it is 7".
8. Use a $\frac{1}{8}$ " space washer and install the left knotter assembly in the same manner as the right knotter assembly (see paragraph No. 6).
9. Use a $\frac{1}{32}$ " space washer and install the #32881 twine finger cam with a $\frac{5}{32} \times \frac{3}{4}$ " woodruff key.
10. Use a $\frac{1}{32}$ " space washer and install the left knotter support bearing. Check the distance between corresponding points on the left and right support bearings and add or remove space washers to make the distance 18" (Fig. 36).
11. Install a $\frac{1}{8}$ " space washer next to the support bearing. Place the knotter brake assembly on the knotter brake disc and install the disc on the knotter shaft, positioning the brake assembly on the locating pins as shown in Fig. 24.
12. Position the $\frac{1}{4} \times \frac{1}{8}$ " woodruff key and install the knotter arm. Attach the brake disc to the knotter arm with a $\frac{5}{16} \times \frac{1}{2}$ " cap screw and lock washer.
13. Install 1" O.D. washers between the knotter shaft and the end cap as needed, to remove all end play from the knotter shaft assembly when the cap screw and the end cap is installed and tightened securely. **Important:** Failure to eliminate end play in the knotter shaft assembly may result in serious knotter damage.
14. Mount the complete knotter shaft assembly on the knotter support bearing brackets with $\frac{1}{2} \times 1$ " machine bolts. Check alignment of cams with rollers, etc.
15. Connect the needle yoke rod to the knotter arm and adjust as described on page 14.

TROUBLE SHOOTING

SUMMARY OF KNOTTER DIFFICULTIES AND CORRECTIVE MEASURES

Some of the possible knotter difficulties and their corrective measures are summarized in detail in the next several pages.

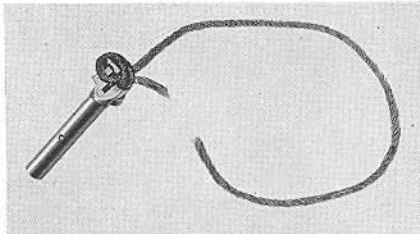
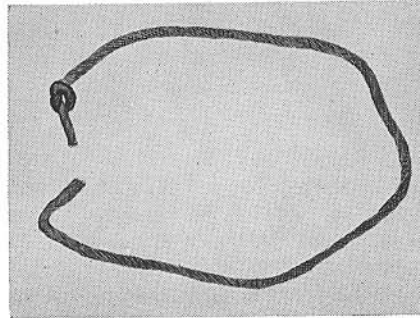
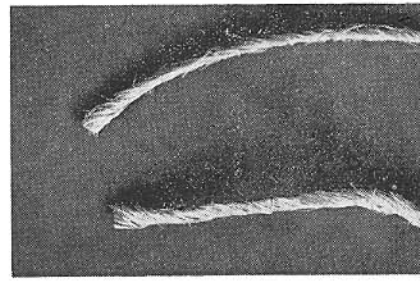
PROBLEM	POSSIBLE CAUSE	CORRECTION
<p>1. KNOTS HANGING ON BILL HOOK</p>  <p>FIGURE 37</p>	<p>Too much tension on bill hook cam.</p> <p>Rough bill hook.</p> <p>Bill hook cam, binding on bill hook adjusting screw.</p> <p>Knife arm stripper does not contact back of bill hook.</p> <p>Knife arm does not rise high enough.</p>	<p>Loosen bill hook cam adjusting screw.</p> <p>Smooth off all rough edges with emery cloth and fine file.</p> <p>File edges smooth in elongated hole in bill hook cam.</p> <p>Bend knife arm stripper so it touches bill hook lightly.</p> <p>Increase lift on knife arm. (See page 20).</p>
<p>2. KNOT TIED ONLY ON ONE END OF TWINE.</p>  <p>FIGURE 38</p>	<p>Twine fingers too far back from needle slot. Too much clearance between twine fingers and needles.</p> <p>Excessive clearance between top of plunger and bale chamber.</p> <p>Plunger dogs not entering bale chamber.</p> <p>Twine disc timing.</p> <p>Bill hook tongue fails to open wide enough.</p> <p>Bent bill hook tongue.</p> <p>Badly worn twine finger cam.</p>	<p>Adjust twine fingers (See page 16). Check the twine finger level for possible bends or broken welds. Check the mounting bolt to make sure that it is tight.</p> <p>Adjust or replace plunger slides.</p> <p>Clean hay and dirt from between plunger dog and bale chamber.</p> <p>Examine plunger dog spring and replace if broken.</p> <p>Advance or retard timing of disc so that both strands are caught in bill hook. (See Page 18).</p> <p>Knotter bill hook roller has worn groove in knotter frame. Replace frame or rebuild groove with weld.</p> <p>Straighten tongue, or replace bill hook.</p> <p>Replace.</p>
<p>3. TWINE CUT OR BROKEN, BUT NO EVIDENCE OF A KNOT IS PRESENT.</p>  <p>FIGURE 39</p>	<p>Tension spring on twine holder does not allow enough twine to slip through holder to form knot.</p> <p>Rough edges on twine holder or disc.</p> <p>Twine tension spring too loose allowing twine to slip out of disc when bill hook turns.</p>	<p>Loosen twine holder tension adjusting screw; clean dust and chaff from under flat twine holder spring.</p> <p>Remove all evidence of sharp edges on twine holder and twine disc.</p> <p>Tighten twine holder spring tension.</p>

TROUBLE SHOOTING

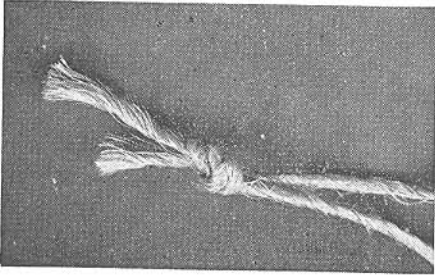
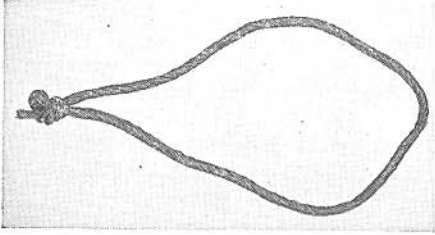
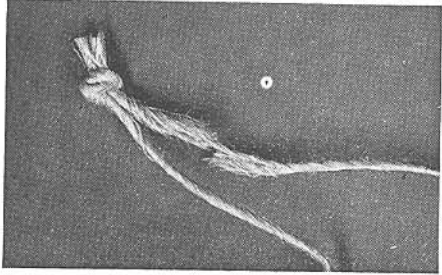
PROBLEM	POSSIBLE CAUSE	CORRECTION
<p>4. ONE END OF TWINE LONGER THAN OTHER OR LOOP IN ONE TWINE END.</p>  <p>FIGURE 40</p>	<p>Dull twine knife.</p> <p>Insufficient tension on twine holder.</p>	<p>Sharpen blade on knife arm.</p> <p>Tighten twine holder tension spring.</p>
 <p>FIGURE 41</p>	<p>Insufficient lift on knife arm.</p> <p>Bale weight too light.</p>	<p>Increase lift on knife arm. (See Page 20).</p> <p>Increase weight by tightening bale tension screws.</p>
<p>5. TWINE FRAYED OR BROKEN APPROXIMATELY 1/2" BACK OF KNOT.</p>  <p>FIGURE 42</p>	<p>Insufficient clearance between back of bill hook and inside face of knife arm.</p>	<p>Bend knife arm so bill hook will revolve freely. However, when the knife arm rises, the strip per arm must touch bill hook.</p>
<p>6. TWINE DISC DOES NOT STAY IN TIME.</p>	<p>Twine disc pinion 11840 Driv-Lok pin sheared.</p> <p>Shaft in twine disc turns in hub.</p> <p>Adjustable knotter worm slips on shaft.</p>	<p>Replace Driv-Lok pin.</p> <p>Replace twine disc assembly.</p> <p>Locknut not tight enough or spacer washer wedged between the shoulder of tapered shaft and worm gear.</p>

TROUBLE SHOOTING

PROBLEM	POSSIBLE CAUSE	CORRECTION
SHEARING FLY WHEEL SAFETY BOLTS.	Bailing too heavy. Safety bolt nut loose. Improper needle timing. Dull knives. Excessive clearance between knives. Worn knotter clutch gear. Worn or improperly adjusted needle and knotter brakes.	Loosen bale tension Tighten safety bolt nut securely. Use jam nut if necessary. Retime the needle drive. Sharpen knives. Adjust knives. (See Page 16). Replace. Clean and adjust brakes, replace worn linings.
FAILURE TO PICK UP MATERIAL CLEAN.	Pick-up too high from ground. Too many pick-up fingers bent or broken. Ground speed too fast. Windrows too light.	Raise auxiliary pick-up wheel. Replace broken and bent pick-up fingers. Slow down. Rake heavier windrows.
SHEARING WADBOARD SAFETY BOLTS.	Improper feeding. Solid object in bale chamber.	Rake smaller uniform windrows. Remove stones, etc.
SHEARING KNOTTER DRIVE BOLTS.	Dirty knotter. Improper adjustment of knotter brakes. Bearing freezing on shaft. Too much end play in knotter stack.	Clean knotters. Adjust brakes (See Page 13). Loosen bearing and lubricate. Adjust end play in knotter stack.
MIS-SHAPED BALES	Improper wadboard penetration. Plunger speed too fast for the particular crop condition. Improper feeding. Worn or damaged wadboard.	Loosen wadboard drive chain and slip chain on the sprockets to adjust penetration of the wadboard. Decrease plunger speed to less than 70 strokes per minute. Rake uniform windrows and regulate ground speed. Replace worn or damaged wooden parts.
RAGGED BALES	Dull knives. Improper knife clearance.	Sharpen knives. Adjust plunger slide angles. (See Page 16).
PICK-UP FINGER STRIKING GROUND AT ALL TIMES.	Insufficient tension on pick-up spring. Improper adjustment of pick-up wheel.	Tighten pick-up lift spring. Move mounting bracket of pick-up wheel lower.
NEEDLE BREAKAGE	Solid objects in needle slots. Mis-adjustment of needle. Worn knotter clutch gear together with mis-adjustment of needle safety latch.	Remove the object and clean slots. Re-adjust needles. (See page 14). Replace clutch gear. Re-adjust needle safety latch.

SPECIAL EQUIPMENT

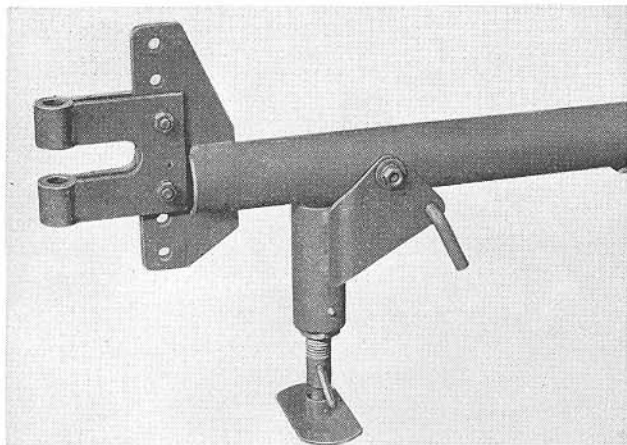

Jack makes hitching and unhitching easier. Swings up out of way in field operation.

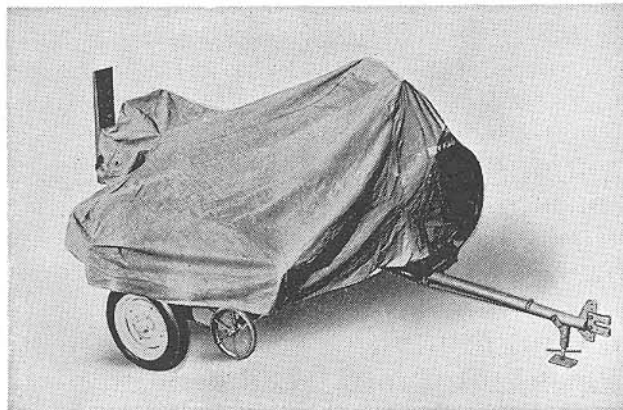

Tailored Cover form-fitted of heavy weather proofed duck. Protects your original investment.

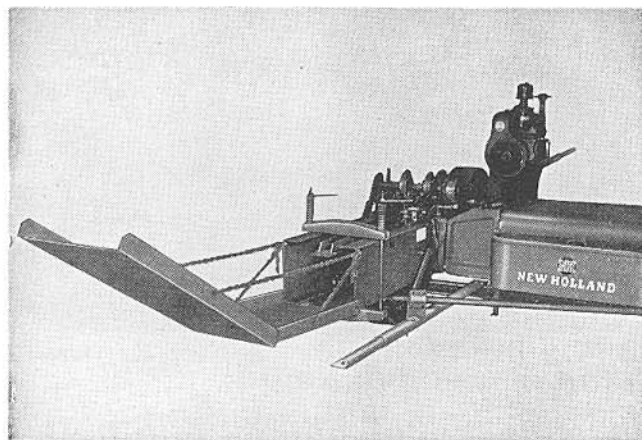

Wagon Loader slides bales up chute extension on to wagon. Telescoping wagon hitch attaches directly to main axle of baler.

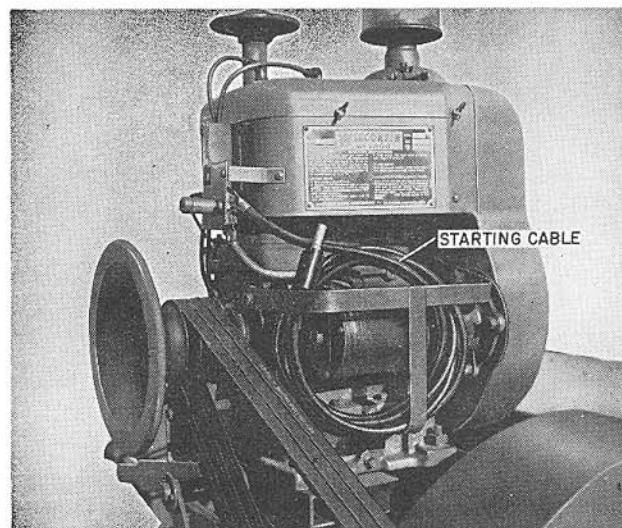

TF-D Engine with electrical starting equipment Cable quickly attaches to tractor for your starting convenience.

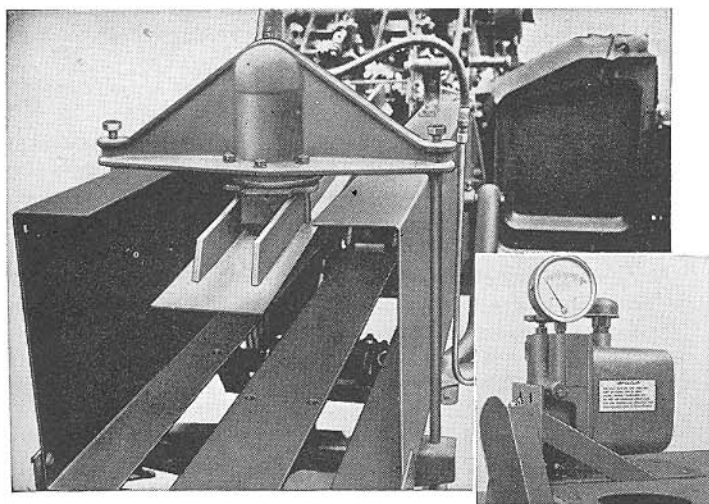

Hydraformatic — the only hydraulic bale tensioning system. It gives you the bale weight you want, regardless of the type of material you're baling.

HYDRAULIC BALE TENSION ATTACHMENT

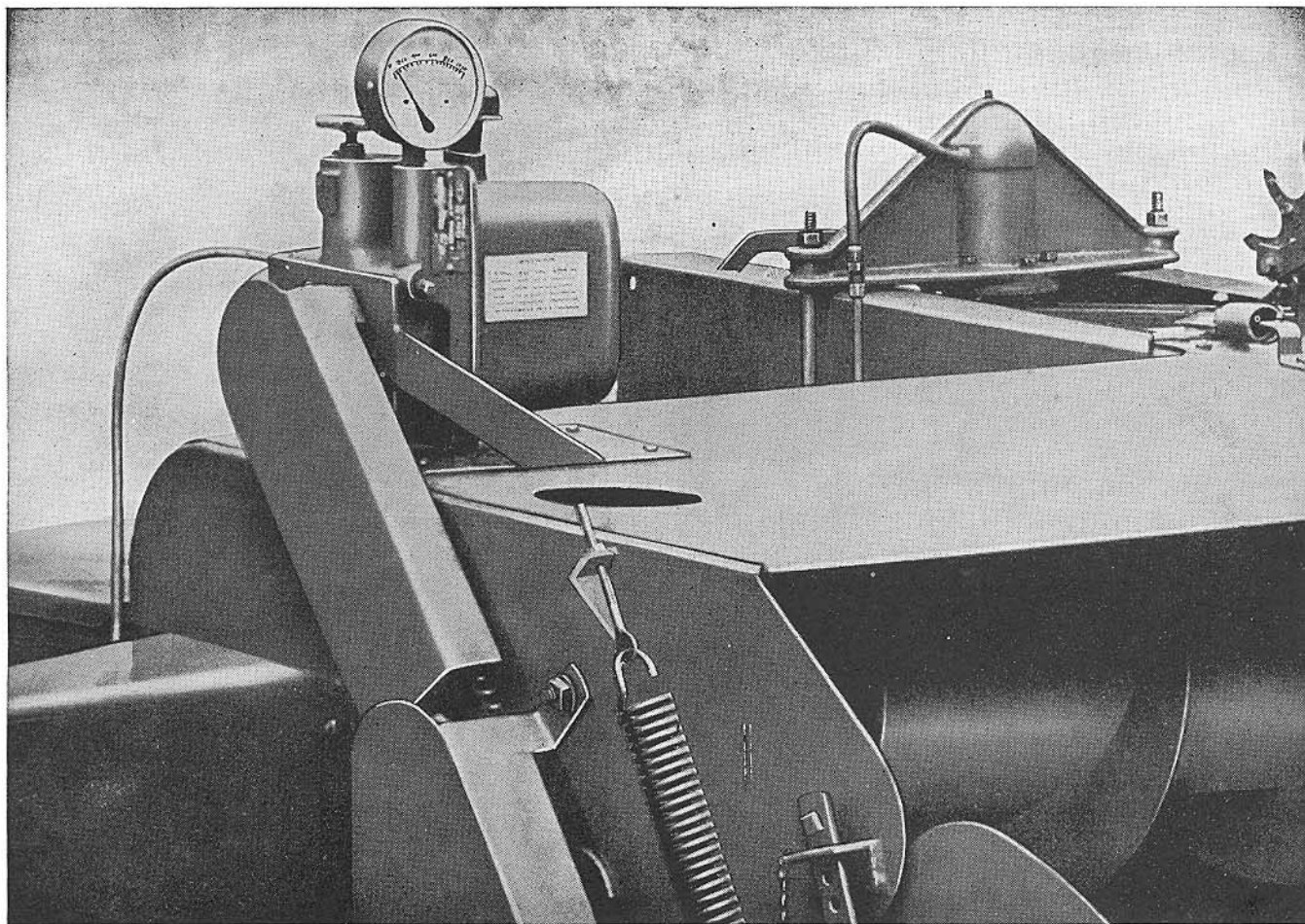

FIGURE 43

OPERATION

Fill the pump reservoir with a high quality motor oil. Use S. A. E. #10 when operating the baler in normal temperatures. For cooler temperatures, thin the oil with kerosene until it flows freely.

Care must be taken to keep the oil clean, and free of dust, water, sealing compounds, etc. Do not use hydraulic brake fluid.

When filling the tank, pour the oil through a 180 mesh wire screen placed in the large end of a funnel. Never use a cloth strainer because all cloth contains lint which is harmful to the hydraulic system.

Before starting the machine, remove all paint and dirt from the threads of the control valve of the pump, turn the control valve in a counter-clockwise direction as far as possible to relieve all pressure from the system, and place a block between the tension rails of the bale chamber.

Never operate the pump without oil.

BLEEDING THE SYSTEM

Start the pump and loosen the pipe plug at the top of the tension cylinder. Retighten the plug when the oil begins to seep out around the threads of the plug. Note: **It is necessary to bleed the system in this way to eliminate air pockets and insure satis-**

factory operation of the unit.

After bleeding the line, refill the oil reservoir to within 1" of the filler opening, and check the action of the pump by turning the control valve clockwise.

STARTING TO BALE

Turn the control valve counter-clockwise as far as possible to remove all pressure from the tension rails of the bale chamber and operate the baler until the bale chamber is full of hay.

With the bale chamber full of hay, turn the control valve clockwise until the gauge registers approximately 100 lbs. of pressure and continue to bale.

After producing several bales, check the weight and density of the bales and re-adjust the control valve on the pump accordingly. As a rule, when only a slight variation in bale weight is desired, $\frac{1}{4}$ to $\frac{1}{2}$ turn of the control valve is sufficient. If a bale of the desired density cannot be produced by regulating the pressure on the hydraulic system, loosen or tighten the nuts on the tension bolts several turns.

It is not possible to state the definite pressure gauge reading required to produce a given weight bale because of the variation in different types of material and the differences in the moisture content of the same crop at different seasons. Experience will teach the operator the correct pressure requirement for particular conditions.

HYDRAULIC BALE TENSION ATTACHMENT

MAINTENANCE

The breather-filler cap is a combination air filter and tank breather which prevents foreign material from entering the hydraulic system and allows air to enter or escape to accommodate the rise or fall of the oil level in the tank. **It is absolutely necessary that this cap be kept clean if it is to do its work properly.**

Remove and clean the breather-filler cap at least after every five days of operation. Wash the cap in kerosene or gasoline and dip it in clean oil before replacing it on the pump. Note: In extremely dusty conditions, more frequent cleaning of the breather cap is necessary.

Several times each season drain the system and remove the oil tank from the pump. Disassemble the oil filter of the pump by removing the eight hollow head cap screws "G". Wash all parts of the pump in kerosene or gasoline and lubricate with clean oil. Make sure that all parts are absolutely clean before re-assembling.

Change oil at least once each season. Drain the oil completely from all parts of the system at this time and refill with clean oil. Caution: When the hose or tubing is disconnected, always cover the open ends to keep out dirt and foreign material.

Keep the pump drive chain moderately tight.

Check the oil level in the pump reservoir at least once each week and fill to within one inch of the

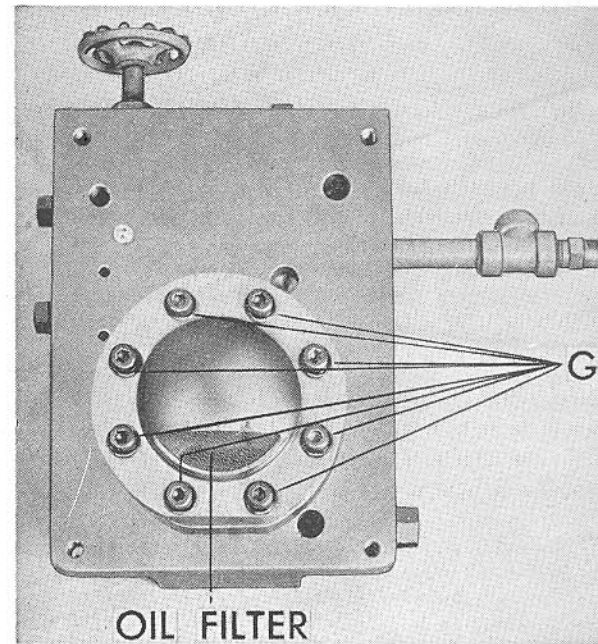

SERVICE CHART

PROBLEM	POSSIBLE CAUSE	CORRECTION
Pump not delivering oil.	Not enough oil in tank. Suction oil filter clogged. Pump driven in wrong direction of rotation.	Add oil as necessary. Remove suction filter and clean thoroughly. Periodic cleaning is recommended. Dis-assemble and reverse #27281 r in which rotor and vanes turn.
Pump not developing sufficient pressure.	Sludge and dirt in unit. Valve surfaces scored by abrasive matter. Leak in hydraulic system connections or leaking cylinder. Too light weight oil.	Flush and clean thoroughly. Replace all worn or scored parts. Eliminate all leaks. Change to heavier oil.
Pump noisy	Partially clogged filter. Breather filler cap plugged. Air in hydraulic system. Drive chain too tight.	Remove, flush, clean filter thoroughly. Remove breather cap, flush and clean. Bleed system at highest point. Check chain tightness.
Excessive oil temperature.	Restriction in hydraulic line causing overloading of pump. Too heavy oil.	Check system for restrictions. Use proper weight oil - thin with k sene if necessary.

BALER MAINTENANCE

ENGINE CARE

Use a good grade motor oil in the engine at all times.

Check the oil level after every eight hours of operation.

Change crankcase oil after every fifty hours of operation.

Service the oil bath of the air filter daily.

Fill the oil reservoir of the air filter to the level indicated on the side of the cup with the same type oil as used in the crankcase.

IMPORTANT: IN NORMAL OPERATING CONDITIONS REMOVE THE ENGINE COVERS WEEKLY AND THOROUGHLY CLEAN THE DIRT AND DUST FROM THE COOLING FINS OF THE ENGINE.

NOTE: MORE FREQUENT CLEANING MAY BE NECESSARY IN EXTREMELY DIRTY CONDITIONS. FAILURE TO KEEP THE AIR PASSAGES CLEAN WILL RESULT IN OVERHEATING OF THE ENGINE WITH CONSEQUENT DAMAGE TO THE CYLINDER WALLS.

GEARBOX

Use S.A.E. #90 E. P. gear oil. Keep the gear box filled to the oil level plug.

Change the oil of the gear box at the beginning of each baling season.

Keep the gearbox mounting bolts tight.

Should a problem arise concerning the gear box, consult an authorized New Holland dealer. **Operators are cautioned not to attempt to repair or adjust the gear box.**

TIRES

Keep the tires properly inflated. Inflate the 6:00 x 16" tire to 36 pounds pressure and the 5:00 x 16" tire to 32 pounds pressure. Check the tire pressure at least once a week when the baler is in use.

DRIVE BELTS

Replace worn drive belts with a complete new set since the sets of these belts are matched for length. The life of all the belts will be greatly shortened if only a single belt is replaced at a time.

A liberal application of talcum powder may be used to prevent a new belt from sticking to the sheave. Do not use belt dressing on "V" belts at anytime. **Keep all belts free of grease and oil.**

P.T.O. DRIVE

Oil the drive pins of the over-running clutch daily with two or three drops of light machine oil. At the beginning of each baling season, dis-assemble the slip clutch and the over-running clutch assemblies and wipe grease on the face of the over-running clutch and the bushings of both clutch assemblies.

Keep the P.T.O. drive tube well lubricated so that the P.T.O. shaft can telescope freely.

Lubricate the universal joints of the P.T.O. drive carefully with one or two pumps of the hand gun twice a week. Caution: Excessive lubrication may damage the grease seals.

ROLLER CHAINS

Oil roller chains on the baler daily with light machine oil.

Keep the chains properly adjusted for most efficient baler operation.

REPLACING PICK-UP FINGERS

To replace pick-up fingers proceed as follows:

1. Remove the chain guard, loosen the idlers, and remove the pick-up drive chain.
2. Remove the mounting bolts from all the sets of teeth on the pick-up drum pipe on which the fingers are to be replaced.
3. Remove all cotter keys.
4. Turn the pick-up to the point where the pick-up cam roller may be removed through the hole in the right side of the pick-up side plate (point B, Fig. 11).
5. Remove the drum pipe through the slot in the side plate, point A.
6. Replace the pick-up fingers on the pick-up drum pipe as it is reinstalled through the end casting of the pick-up drum assembly.
7. Position the pick-up drum pipe and install the cam roller. **Make sure that the cam rollers follow the drum pipes in the direction of pick-up travel.**
8. Reinstall all cotter keys and bolt the pick-up fingers to the drum pipe.

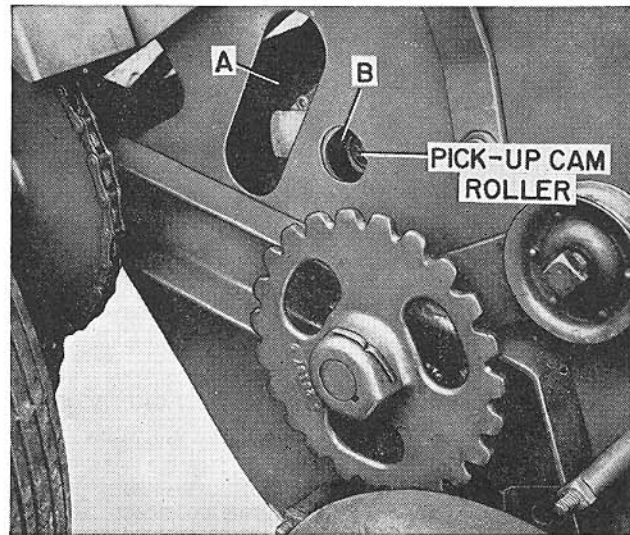

FIGURE 45

DAILY CARE OF THE BALER

Clean dust, dirt, hay blossoms, etc., from the machine daily to insure proper operation.

Check the entire baler for loose bolts, loose chains, etc.

Inspect the slicing knives for adjustment and sharpness.

Oil the roller chains and all linkage.

Keep the bearings well lubricated.

Release the tension rails at the end of each day's operation to remove the pressure from the material in the bale chamber.

STORING THE BALER

1. At the close of the baling season remove the material from the bale chamber and coat the bale chamber and the knotters lightly with grease to prevent rusting.
2. Remove the roller chains from the machine and clean thoroughly by soaking them in kerosene. Coat with heavy oil or grease before storing. Reclean the chains and apply a light coating of oil before using again.
3. Remove the "V" belts, wipe clean, and store in a cool dry place.
4. Place the baler on blocks to remove the load from the wheels when the machine is stored to increase the life of the tires.
5. Service the engine as instructed in the engine manual.
6. Provide adequate protection from the weather.
7. It is a good practice to have the baler inspected at the end of each season and the complete machine put in top condition. At this time worn chains, sprockets, bearings, wooden slides, etc., should be replaced and other necessary adjustments made.

*NOTE: Your authorized New Holland dealer will be glad to inspect and service your machine for you. A periodic check-up in his shop will help to keep your maintenance costs at a minimum.

ORDERING PARTS

When preparing the baler for storage, check the baler thoroughly for any parts that may have become worn and need replacing. USE THE CHECK LIST TO ASSIST IN MAKING A LIST OF THE PARTS NEEDED AT THIS TIME.

Service parts should be ordered at once and installed before the next baling season.

When ordering service parts, always be sure to give your New Holland dealer the model and serial number of your baler, as well as the quantity, part number and an accurate description of each part.

The plate containing the model and serial number of the baler is located on the front end of the baler frame beside the flywheel. In case this should become lost, the number is also stamped on the left side of the bale chamber beside the crank arm cover.

INSIST ON GENUINE NEW HOLLAND SERVICE PARTS. FOR BEST PERFORMANCE HAVE YOUR BALER SERVICED BY AN AUTHORIZED NEW HOLLAND DEALER.

Note A — An extra set of slicing knives (parts number 29127 and 29128) is a good investment. Dull knives can then be sharpened while the spare set is being used.

CHECK LIST FOR ORDERING SERVICE PARTS

1. Check the slicing knives (See note A).
2. Examine the wooden slides of the plunger and the slides of the feeder plunger.
3. Inspect the wadboard assembly for wear or damage.
4. Examine all belts, chains, and sprockets for wear (See note B).
5. Inspect the draw bar hook-up clevis for excessive wear.
6. Check all bearings for wear in the bushings.
7. Inspect the plunger and the connecting rod.
8. Examine the complete knotter assembly and check for excessive wear at any point; especially note the rollers on the assembly, bill hooks, bill hook cams, twine finger cams, etc.
9. Note any broken or bent pick-up fingers.
10. Make sure the cam rollers of the pick-up assembly are in good condition.

Note B—Replace V drive belts in complete set and replace worn sprockets when installing new roller chains.